

Current Electricity

Electric Current

(1) **Definition** : The time rate of flow of charge through any cross-section is called current. So if through a cross-section, ΔQ charge passes in time Δt then $i_{av} = \frac{\Delta Q}{\Delta t}$ and instantaneous current $i = \lim_{\Delta t \rightarrow 0} \frac{\Delta Q}{\Delta t} = \frac{dQ}{dt}$. If flow is uniform then $i = \frac{Q}{t}$. Current is a scalar quantity. It's S.I. unit is *ampere* (A) and C.G.S. unit is *emu* and is called *biot* (Bi), or *ab ampere*. $1A = (1/10) Bi$ (*ab amp.*)

(2) **The direction of current** : The conventional direction of current is taken to be the direction of flow of positive charge, i.e. field and is opposite to the direction of flow of negative charge as shown below.



Though conventionally a direction is associated with current (Opposite to the motion of electron), it is not a vector. It is because the current can be added algebraically. Only scalar quantities can be added algebraically not the vector quantities.

(3) **Charge on a current carrying conductor** : In conductor the current is caused by electron (free electron). The no. of electron (negative charge) and proton (positive charge) in a conductor is same. Hence the net charge in a current carrying conductor is zero.

(4) **Current through a conductor of non-uniform cross-section** : For a given conductor current does not change with change in cross-sectional area. In the following figure $i_1 = i_2 = i_3$

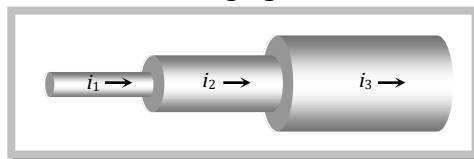

(5) **Types of current** : Electric current is of two type :

Alternating current (ac)	Direct current (dc)
(i) Magnitude and direction both varies with time ac \rightarrow Rectifier \rightarrow dc	(i) (Pulsating dc) (Constant dc) dc \rightarrow Inverter \rightarrow ac
(ii) Shows heating effect only	(ii) Shows heating effect, chemical effect and magnetic effect of current
(iii) It's symbol is	(iii) It's symbol is

:□ In our houses ac is supplied at 220V, 50Hz.

(6) Current in different situations :

(i) Due to translatory motion of charge

In n particles each having a charge q , pass through a given area in time t then $i = \frac{nq}{t}$

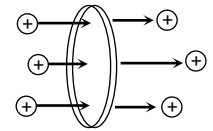

If n particles each having a charge q pass per second per unit area, the current associated with cross-sectional area A is $i = nqA$

If there are n particles per unit volume each having a charge q and moving with velocity v , the current through cross-section A is $i = nqvA$

(ii) Due to rotatory motion of charge

If a point charge q is moving in a circle of radius r with speed v (frequency ν , angular speed ω and time period T) then corresponding currents $i = qv = \frac{q}{T} = \frac{qv}{2\pi r} = \frac{q\omega}{2\pi}$

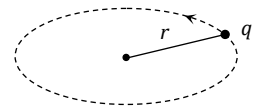

(iii) When a voltage V applied across a resistance R : Current flows through the conductor $i = \frac{V}{R}$ also by

definition of power $i = \frac{P}{V}$

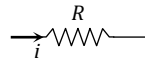

(7) **Current carriers** : The charged particles whose flow in a definite direction constitutes the electric current are called current carriers. In different situations current carriers are different.

(i) Solids : In solid conductors like metals current carriers are free electrons.

(ii) Liquids : In liquids current carriers are positive and negative ions.

(iii) Gases : In gases current carriers are positive ions and free electrons.

(iv) Semi conductor : In semi conductors current carriers are holes and free electrons.

Current density (\vec{J})

In case of flow of charge through a cross-section, current density is defined as a vector having magnitude equal to current per unit area surrounding that point. Remember area is normal to the direction of charge flow (or current passes) through that point. Current density at point P is given by $\vec{J} = \frac{di}{dA} \vec{n}$

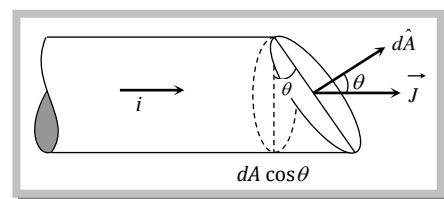
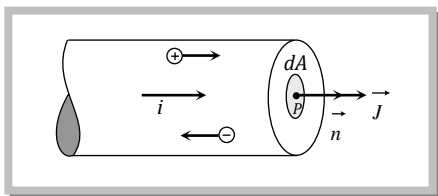

If the cross-sectional area is not normal to the current, the cross-sectional area normal to current in accordance with following figure will be $dA \cos \theta$ and so in this situation:

$$J = \frac{di}{dA \cos \theta} \quad \text{i.e. } di = J dA \cos \theta \quad \text{or } di = \vec{J} \cdot \vec{dA} \Rightarrow i = \int \vec{J} \cdot \vec{dA}$$

i.e., in terms of current density, current is the flux of current density.

□ If current density \vec{J} is uniform for a normal cross-section \vec{A} then : $i = \int \vec{J} \cdot \vec{ds} = \vec{J} \cdot \int \vec{ds}$ [as $\vec{J} = \text{constant}$]

$$\text{or } i = \vec{J} \cdot \vec{A} = JA \cos \theta = JA \Rightarrow J = \frac{i}{A} \quad [\text{as } \int d\vec{A} = \vec{A} \text{ and } \theta = 0^\circ]$$

(1) **Unit and dimension** : Current density \vec{J} is a vector quantity having S.I. unit Amp/m^2 and dimension, $[L^{-2}A]$

(2) **Current density in terms of velocity of charge** : In case of uniform flow of charge through a cross-section normal to it as $i = nqvA$ so, $\vec{J} = \frac{i}{A} \vec{n} = (nqv) \vec{n}$ or $\vec{J} = nq\vec{v} = \vec{v}(\rho)$ [With $\rho = \frac{\text{charge}}{\text{volume}} = nq$]

i.e., current density at a point is equal to the product of volume charge density with velocity of charge distribution at that point.

(3) **Current density in terms of electric field** : Current density relates with electric field as $J = \sigma E = \frac{E}{\rho}$;

where $\sigma =$ conductivity and $\rho =$ resistivity or specific resistance of substance.

(i) Direction of current density \vec{J} is same as that of electric field \vec{E} .

(ii) If electric field is uniform (*i.e.* $\vec{E} = \text{constant}$) current density will be constant [as $\sigma = \text{constant}$]

(iii) If electric field is zero (as in electrostatics inside a conductor), current density and hence current will be zero.

Conduction of Current in Metals.

According to modern views, a metal consists of a 'lattice' of fixed positively charged ions in which billions and billions of free electrons are moving randomly at speed which at room temperature (*i.e.* 300 K) in accordance with

kinetic theory of gases is given by $v_{rms} = \sqrt{\frac{3kT}{m}} = \sqrt{\frac{3 \times (1.38 \times 10^{-23}) \times 300}{9.1 \times 10^{-31}}} \approx 10^5 \text{ m/s}$

The randomly moving free electrons inside the metal collide with the lattice and follow a zig-zag path as shown in figure (A).

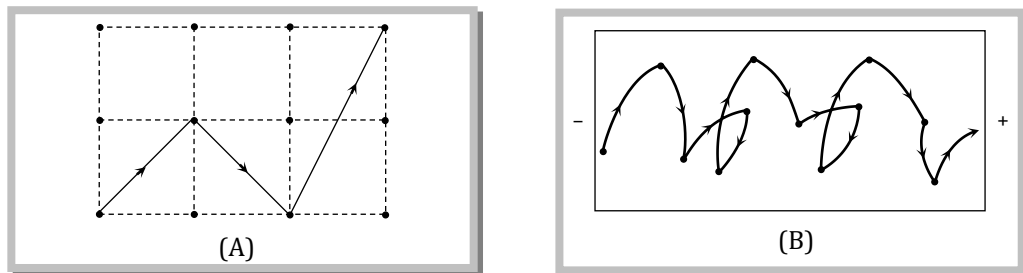

However, in absence of any electric field due to this random motion, the number of electrons crossing from left to right is equal to the number of electrons crossing from right to left (otherwise metal will not remain equipotential) so the net current through a cross-section is zero.

When an electric field is applied, inside the conductor due to electric force the path of electron in general becomes curved (parabolic) instead of straight lines and electrons drift opposite to the field figure (B). Due to this drift the random motion of electrons get modified and there is a net transfer of electrons across a cross-section resulting in current.

(1) **Drift velocity** : Drift velocity is the average uniform velocity acquired by free electrons inside a metal by the application of an electric field which is responsible for current through it. Drift velocity is very small it is of the order of 10^{-4} m/s as compared to thermal speed ($\approx 10^5 \text{ m/s}$) of electrons at room temperature.

If suppose for a conductor

$n =$ Number of electron per unit volume of the conductor

$A =$ Area of cross-section

$V =$ potential difference across the conductor

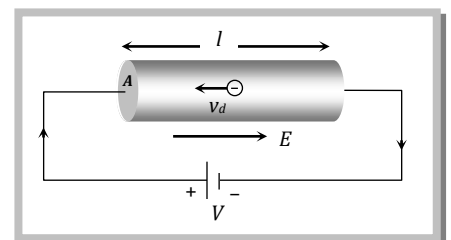

E = electric field inside the conductor

i = current, J = current density, ρ = specific resistance, σ = conductivity $\left(\sigma = \frac{1}{\rho}\right)$ then current relates with

drift velocity as $i = neAv_d$ we can also write $v_d = \frac{i}{neA} = \frac{J}{ne} = \frac{\sigma E}{ne} = \frac{E}{\rho ne} = \frac{V}{\rho l ne}$.

- ❑ The direction of drift velocity for electron in a metal is opposite to that of applied electric field (i.e. current density \vec{J}).
- ❑ $v_d \propto E$ i.e., greater the electric field, larger will be the drift velocity.
- ❑ When a steady current flows through a conductor of non-uniform cross-section drift velocity varies inversely with area of cross-section $\left(v_d \propto \frac{1}{A}\right)$
- ❑ If diameter of a conductor is doubled, then drift velocity of electrons inside it will not change.

(2) **Relaxation time (τ)** : The time interval between two successive collisions of electrons with the positive ions in the metallic lattice is defined as relaxation time $\tau = \frac{\text{mean free path}}{\text{r.m.s. velocity of electrons}} = \frac{\lambda}{v_{rms}}$ with rise in temperature v_{rms} increases consequently τ decreases.

(3) **Mobility** : Drift velocity per unit electric field is called mobility of electron i.e. $\mu = \frac{v_d}{E}$. Its unit is $\frac{m^2}{\text{volt} - \text{sec}}$.

Concepts

- ☞ Human body, though has a large resistance of the order of $k\Omega$ (say $10 k\Omega$), is very sensitive to minute currents even as low as a few mA. Electrocutation, excites and disorders the nervous system of the body and hence one fails to control the activity of the body.
- ☞ 1 ampere of current means the flow of 6.25×10^{18} electrons per second through any cross-section of the conductors.
- ☞ dc flows uniformly throughout the cross-section of conductor while ac mainly flows through the outer surface area of the conductor. This is known as skin effect.
- ☞ It is worth noting that electric field inside a charged conductor is zero, but it is non zero inside a current carrying conductor and is given by $E = \frac{V}{l}$ where V = potential difference across the conductor and l = length of the conductor. Electric field outside the current carrying is zero.

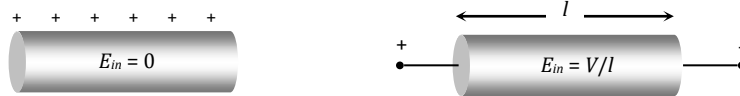

- ☞ For a given conductor $JA = i = \text{constant}$ so that $J \propto \frac{1}{A}$ i.e., $J_1 A_1 = J_2 A_2$; this is called equation of continuity

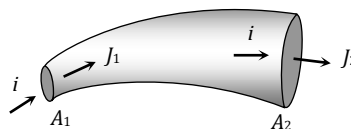

- ☞ If cross-section is constant, $I \propto J$ i.e. for a given cross-sectional area, greater the current density, larger will be current.
- ☞ The drift velocity of electrons is small because of the frequent collisions suffered by electrons.
- ☞ The small value of drift velocity produces a large amount of electric current, due to the presence of extremely large number of free electrons in a conductor. The propagation of current is almost at the speed of light and involves electromagnetic process. It is due to this reason that the electric bulb glows immediately when switch is on.
- ☞ In the absence of electric field, the paths of electrons between successive collisions are straight line while in presence of electric field the paths are generally curved.
- ☞ Free electron density in a metal is given by $n = \frac{N_A x d}{A}$ where N_A = Avogadro number, x = number of free electrons per atom, d =

density of metal and A = Atomic weight of metal.

Example

Example: 1 The potential difference applied to an X-ray tube is 5 KV and the current through it is 3.2 mA. Then the number of electrons striking the target per second is

- (a) 2×10^{16} (b) 5×10^6 (c) 1×10^{17} (d) 4×10^{15}

Solution : (a) $i = \frac{q}{t} = \frac{ne}{t} \Rightarrow n = \frac{it}{e} = \frac{3.2 \times 10^{-3} \times 1}{1.6 \times 10^{-19}} = 2 \times 10^{16}$

Example: 2 A beam of electrons moving at a speed of 10^6 m/s along a line produces a current of 1.6×10^{-6} A. The number of electrons in the 1 metre of the beam is

- (a) 10^6 (b) 10^7 (c) 10^{13} (d) 10^{19}

Solution : (b) $i = \frac{q}{t} = \frac{qv}{(x/v)} = \frac{qv}{x} = \frac{nev}{x} \Rightarrow n = \frac{ix}{ev} = \frac{1.6 \times 10^{-6} \times 1}{1.6 \times 10^{-19} \times 10^6} = 10^7$

Example: 3 In the Bohr's model of hydrogen atom, the electrons moves around the nucleus in a circular orbit of a radius 5×10^{-11} metre. It's time period is 1.5×10^{-16} sec. The current associated is

- (a) Zero (b) 1.6×10^{-19} A (c) 0.17 A (d) 1.07×10^{-3} A

Solution : (d) $i = \frac{q}{T} = \frac{1.6 \times 10^{-19}}{1.5 \times 10^{-16}} = 1.07 \times 10^{-3}$ A

Example: 4 An electron is moving in a circular path of radius 5.1×10^{-11} m at a frequency of 6.8×10^{15} revolution/sec. The equivalent current is approximately

- (a) 5.1×10^{-3} A (b) 6.8×10^{-3} A (c) 1.1×10^{-3} A (d) 2.2×10^{-3} A

Solution : (c) $v = 6.8 \times 10^{15} \Rightarrow T = \frac{1}{6.8 \times 10^{15}} \text{ sec} \Rightarrow i = \frac{Q}{T} = 1.6 \times 10^{-19} \times 6.8 \times 10^{15} = 1.1 \times 10^{-3}$ A

Example: 5 A copper wire of length 1m and radius 1mm is joined in series with an iron wire of length 2m and radius 3mm and a current is passed through the wire. The ratio of current densities in the copper and iron wire is

- (a) 18 : 1 (b) 9 : 1 (c) 6 : 1 (d) 2 : 3

Solution : (b) We know $J = \frac{i}{A}$ when i = constant $J \propto \frac{1}{A} \Rightarrow \frac{J_c}{J_i} = \frac{A_i}{A_c} = \left(\frac{r_i}{r_c}\right)^2 = \left(\frac{3}{1}\right)^2 = \frac{9}{1}$

Example: 6 A conducting wire of cross-sectional area 1 cm^2 has $3 \times 10^{23} \text{ m}^{-3}$ charge carriers. If wire carries a current of 24 mA, the drift speed of the carrier is

- (a) 5×10^{-6} m/s (b) 5×10^{-3} m/s (c) 0.5 m/s (d) 5×10^{-2} m/s

Solution : (b) $v_d = \frac{i}{neA} = \frac{24 \times 10^{-3}}{3 \times 10^{23} \times 1.6 \times 10^{-19} \times 10^{-4}} = 5 \times 10^{-3} \text{ m/s}$

Example: 7 A wire has a non-uniform cross-sectional area as shown in figure. A steady current i flows through it. Which one of the following statement is correct

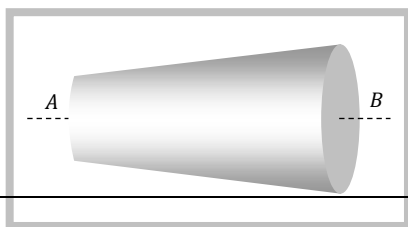

is (Given density of Cu is 9 gm/cm^3 , atomic weight of Cu is 63 grams and one free electron is contributed by each atom)

- (a) 0.1 mm/sec (b) 0.2 mm/sec (c) 0.3 mm/sec (d) 0.5 mm/sec

Solution: (a) 6.023×10^{23} atoms has mass = $63 \times 10^{-3} \text{ kg}$

$$\text{So no. of atoms per } m^3 = n = \frac{6.023 \times 10^{23}}{63 \times 10^{-3}} \times 9 \times 10^3 = 8.5 \times 10^{28}$$

$$v_d = \frac{i}{neA} = \frac{1.1}{8.5 \times 10^{28} \times 1.6 \times 10^{-19} \times \pi \times (0.5 \times 10^{-3})^2} = 0.1 \times 10^{-3} \text{ m/sec} = 0.1 \text{ mm/sec}$$

Ohm's Law.

If the physical circumstances of the conductor (length, temperature, mechanical strain etc.) remains constant, then the current flowing through the conductor is directly proportional to the potential difference across it's two ends i.e. $i \propto V$

$$\Rightarrow V = iR \text{ or } \frac{V}{i} = R; \text{ where } R \text{ is a proportionality constant, known as electric resistance.}$$

(1) Ohm's law is not a universal law, the substance which obeys ohm's law are known as ohmic substance for such ohmic substances graph between V and i is a straight line as shown. At different temperatures V - i curves are different.

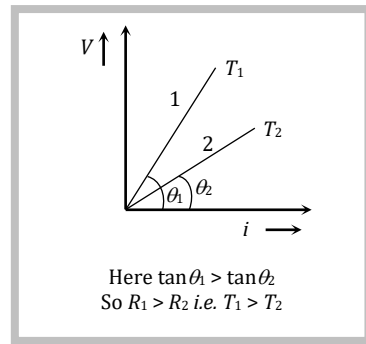
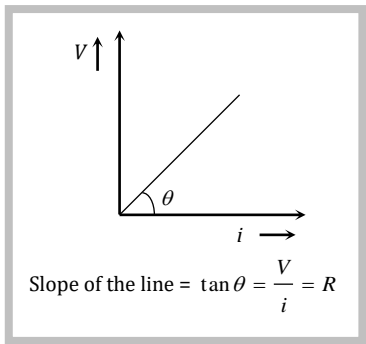

(2) The device or substances which doesn't obey ohm's law e.g. gases, crystal rectifiers, thermoionic valve, transistors etc. are known as non-ohmic or non-linear conductors. For these V - i curve is not linear. In these situation the ratio between voltage and current at a particular voltage is known as static resistance. While the rate of change of voltage to change in current is known as dynamic resistance.

$$R_{st} = \frac{V}{i} = \frac{1}{\tan \theta}$$

$$\text{while } R_{dyn} = \frac{\Delta V}{\Delta I} = \frac{1}{\tan \phi}$$

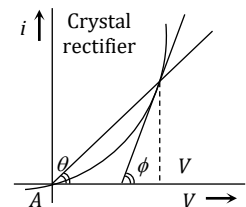

(3) Some other non-ohmic graphs are as follows :

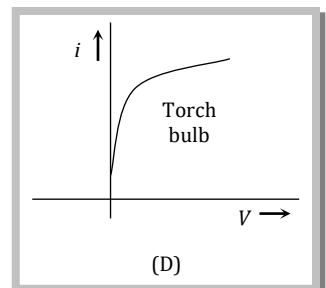
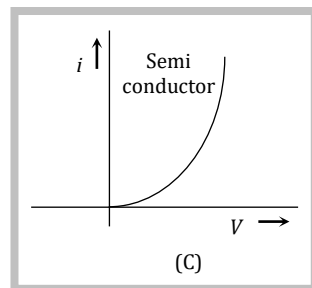
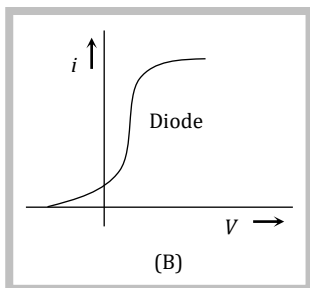
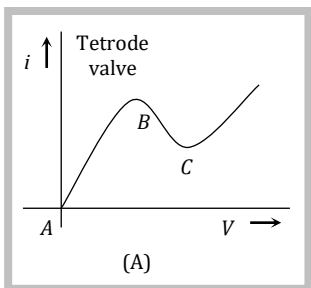

Resistance.

(1) **Definition** : The property of substance by virtue of which it opposes the flow of current through it, is known as the resistance.

(2) **Cause of resistance of a conductor** : It is due to the collisions of free electrons with the ions or atoms of the conductor while drifting towards the positive end of the conductor.

(3) **Formula of resistance** : For a conductor if l = length of a conductor A = Area of cross-section of conductor, n = No. of free electrons per unit volume in conductor, τ = relaxation time then resistance of conductor $R = \rho \frac{l}{A} = \frac{m}{ne^2\tau} \cdot \frac{l}{A}$; where ρ = resistivity of the material of conductor

(4) **Unit and dimension** : It's S.I. unit is Volt/Amp. or Ohm (Ω). Also $1 \text{ ohm} = \frac{1 \text{ volt}}{1 \text{ Amp}} = \frac{10^8 \text{ emu of potential}}{10^{-1} \text{ emu of current}} = 10^9$ emu of resistance. It's dimension is $[ML^2T^{-3}A^{-2}]$.

(5) **Conductance (C)** : Reciprocal of resistance is known as conductance. $C = \frac{1}{R}$ It's unit is $\frac{1}{\Omega}$ or Ω^{-1} or "Siemen".

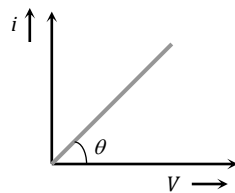

$$\text{Slope} = \tan \theta = \frac{i}{V} = \frac{1}{R} = C$$

(6) **Dependence of resistance** : Resistance of a conductor depends on the following factors.

(i) Length of the conductor : Resistance of a conductor is directly proportional to its length *i.e.* $R \propto l$ *e.g.* a conducting wire having resistance R is cut in n equal parts. So resistance of each part will be $\frac{R}{n}$.

(ii) Area of cross-section of the conductor : Resistance of a conductor is inversely proportional to its area of cross-section *i.e.* $R \propto \frac{1}{A}$

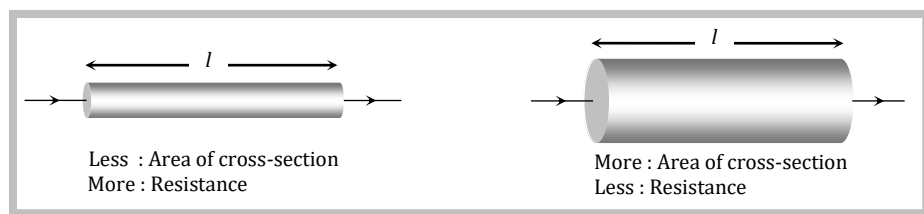

(iii) Material of the conductor : Resistance of conductor also depends upon the nature of material *i.e.* $R \propto \frac{1}{n}$, for different conductors n is different. Hence R is also different.

(iv) Temperature : We know that $R = \frac{m}{ne^2\tau} \cdot \frac{l}{A} \Rightarrow R \propto \frac{l}{\tau}$ when a metallic conductor is heated, the atom in the metal vibrate with greater amplitude and frequency about their mean positions. Consequently the number of collisions between free electrons and atoms increases. This reduces the relaxation time τ and increases the value of resistance R *i.e.* for a conductor

Resistance \propto temperature .

If R_0 = resistance of conductor at 0°C
 R_t = resistance of conductor at $t^\circ\text{C}$

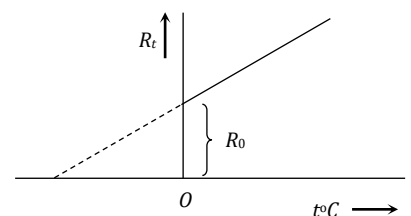

and $\alpha, \beta =$ temperature co-efficient of resistance (unit \rightarrow per $^{\circ}C$)

then $R_t = R_0(1 + \alpha t + \beta t^2)$ for $t > 300^{\circ}C$ and $R_t = R_0(1 + \alpha t)$ for $t \leq 300^{\circ}C$ or $\alpha = \frac{R_t - R_0}{R_0 \times t}$

□ If R_1 and R_2 are the resistances at $t_1^{\circ}C$ and $t_2^{\circ}C$ respectively then $\frac{R_1}{R_2} = \frac{1 + \alpha t_1}{1 + \alpha t_2}$.

□ The value of α is different at different temperature. Temperature coefficient of resistance averaged over the temperature range $t_1^{\circ}C$ to $t_2^{\circ}C$ is given by $\alpha = \frac{R_2 - R_1}{R_1(t_2 - t_1)}$ which gives $R_2 = R_1 [1 + \alpha (t_2 - t_1)]$. This formula gives an approximate value.

(v) **Resistance according to potential difference** : Resistance of a conducting body is not unique but depends on it's length and area of cross-section *i.e.* how the potential difference is applied. See the following figures

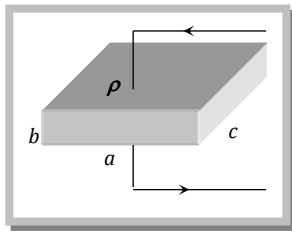

Length = b

Area of cross-section = $a \times c$

$$\text{Resistance } R = \rho \left(\frac{b}{a \times c} \right)$$

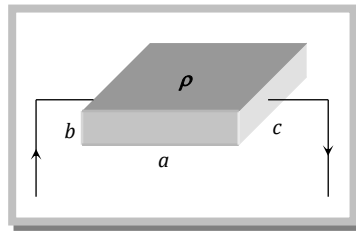

Length = a

Area of cross-section = $b \times c$

$$\text{Resistance } R = \rho \left(\frac{a}{b \times c} \right)$$

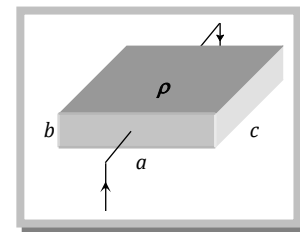

Length = c

Area of cross-section = $a \times b$

$$\text{Resistance } R = \rho \left(\frac{c}{a \times b} \right)$$

(7) Variation of resistance of some electrical material with temperature :

(i) Metals : For metals their temperature coefficient of resistance $\alpha > 0$. So resistance increases with temperature.

Physical explanation : Collision frequency of free electrons with the immobile positive ions increases

(ii) Solid non-metals : For these $\alpha = 0$. So resistance is independence of temperature.

Physical explanation : Complete absence of free electron.

(iii) Semi-conductors : For semi-conductor $\alpha < 0$ *i.e.* resistance decreases with temperature rise.

Physical explanation : Covalent bonds breaks, liberating more free electron and conduction increases.

(iv) Electrolyte : For electrolyte $\alpha < 0$ *i.e.* resistance decreases with temperature rise.

Physical explanation : The degree of ionisation increases and solution becomes less viscous.

(v) Ionised gases : For ionised gases $\alpha < 0$ *i.e.* resistance decreases with temperature rise.

Physical explanation : Degree of ionisation increases.

(vi) Alloys : For alloys α has a small positive values. So with rise in temperature resistance of alloys is almost constant. Further alloy resistances are slightly higher than the pure metals resistance.

Alloys are used to made standard resistances, wires of resistance box, potentiometer wire, meter bridge wire *etc.*

Commonly used alloys are : Constantan, mangnin, Nichrome *etc.*

(vii) Super conductors : At low temperature, the resistance of certain substances becomes exactly zero. (*e.g.* Hg below 4.2 K or Pb below 7.2 K).

These substances are called super conductors and phenomenon super conductivity. The temperature at which resistance becomes zero is called critical temperature and depends upon the nature of substance.

Resistivity or Specific Resistance (ρ)

(1) **Definition** : From $R = \rho \frac{l}{A}$; If $l = 1m$, $A = 1 m^2$ then $R = \rho$ i.e. resistivity is numerically equal to the resistance of a substance having unit area of cross-section and unit length.

(2) **Unit and dimension** : It's S.I. unit is $ohm \times m$ and dimension is $[ML^3T^{-3}A^{-2}]$

(3) **It's formula** : $\rho = \frac{m}{ne^2\tau}$

(4) **It's dependence** : Resistivity is the intrinsic property of the substance. It is independent of shape and size of the body (i.e. l and A). It depends on the followings :

(i) Nature of the body : For different substances their resistivity also different e.g. $\rho_{silver} = \text{minimum} = 1.6 \times 10^{-8} \Omega\text{-m}$ and $\rho_{fused\ quartz} = \text{maximum} \approx 10^{16} \Omega\text{-m}$

(ii) Temperature : Resistivity depends on the temperature. For metals $\rho_t = \rho_0 (1 + \alpha\Delta t)$ i.e. resistivity increases with temperature.

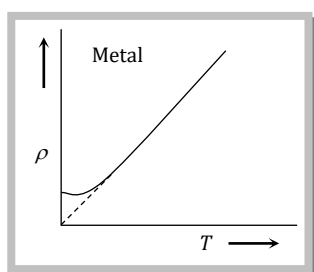

ρ increases with temperature

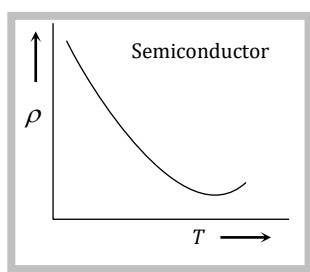

ρ decreases with temperature

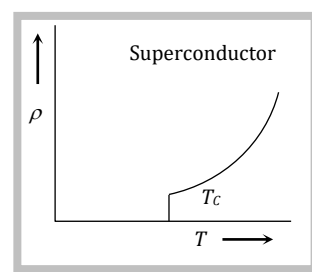

ρ decreases with temperature and becomes zero at a certain temperature

(iii) Impurity and mechanical stress : Resistivity increases with impurity and mechanical stress.

(iv) Effect of magnetic field : Magnetic field increases the resistivity of all metals except iron, cobalt and nickel.

(v) Effect of light : Resistivity of certain substances like selenium, cadmium, sulphides is inversely proportional to intensity of light falling upon them.

(5) **Resistivity of some electrical material** : $\rho_{insulator} > \rho_{alloy} > \rho_{semi-conductor} > \rho_{conductor}$
(Maximum for fused quartz) (Minimum for silver)

□ Reciprocal of resistivity is called conductivity (σ) i.e. $\sigma = \frac{1}{\rho}$ with unit mho/m and dimensions $[M^{-1}L^{-3}T^3A^2]$.

Stretching of Wire

If a conducting wire stretches, it's length increases, area of cross-section decreases so resistance increases but volume remain constant.

Suppose for a conducting wire before stretching its length = l_1 , area of cross-section = A_1 , radius = r_1 , diameter = d_1 , and resistance $R_1 = \rho \frac{l_1}{A_1}$

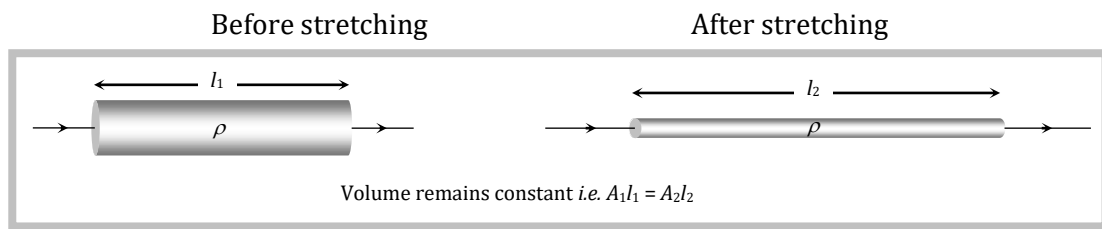

After stretching length = l_2 , area of cross-section = A_2 , radius = r_2 , diameter = d_2 and resistance = $R_2 = \rho \frac{l_2}{A_2}$

Ratio of resistances
$$\frac{R_1}{R_2} = \frac{l_1}{l_2} \times \frac{A_2}{A_1} = \left(\frac{l_1}{l_2}\right)^2 = \left(\frac{A_2}{A_1}\right)^2 = \left(\frac{r_2}{r_1}\right)^4 = \left(\frac{d_2}{d_1}\right)^4$$

(1) If length is given then $R \propto l^2 \Rightarrow \frac{R_1}{R_2} = \left(\frac{l_1}{l_2}\right)^2$

(2) If radius is given then $R \propto \frac{1}{r^4} \Rightarrow \frac{R_1}{R_2} = \left(\frac{r_2}{r_1}\right)^4$

- After stretching if length increases by n times then resistance will increase by n^2 times i.e. $R_2 = n^2 R_1$. Similarly if radius be reduced to $\frac{1}{n}$ times then area of cross-section decreases $\frac{1}{n^2}$ times so the resistance becomes n^4 times i.e. $R_2 = n^4 R_1$.
- After stretching if length of a conductor increases by $x\%$ then resistance will increase by $2x\%$ (valid only if $x < 10\%$)

Various Electrical Conducting Material For Specific Use.

(1) **Filament of electric bulb** : Is made up of tungsten which has high resistivity, high melting point.

(2) **Element of heating devices (such as heater, geyser or press)** : Is made up of nichrome which has high resistivity and high melting point.

(3) **Resistances of resistance boxes (standard resistances)** : Are made up of manganin, or constantan as these materials have moderate resistivity which is practically independent of temperature so that the specified value of resistance does not alter with minor changes in temperature.

(4) **Fuse-wire** : Is made up of tin-lead alloy (63% tin + 37% lead). It should have low melting point and high resistivity. It is used in series as a safety device in an electric circuit and is designed so as to melt and thereby open the circuit if the current exceeds a predetermined value due to some fault. The function of a fuse is independent of its length.

Safe current of fuse wire relates with its radius as $i \propto r^{3/2}$.

(5) **Thermistors** : A thermistor is a heat sensitive resistor usually prepared from oxides of various metals such as nickel, copper, cobalt, iron etc. These compounds are also semi-conductor. For thermistors α is very high which may be positive or negative. The resistance of thermistors changes very rapidly with change of temperature.

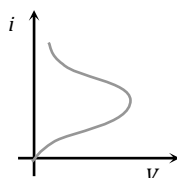

Thermistors are used to detect small temperature change and to measure very low temperature.

Concepts

In the absence of radiation loss, the time in which a fuse will melt does not depend on its length but varies with radius as $t \propto r^4$.

If length (l) and mass (m) of a conducting wire is given then $R \propto \frac{l^2}{m}$.

Macroscopic form of Ohm's law is $R = \frac{V}{i}$, while its microscopic form is $J = \sigma E$.

Example

Example: 12 Two wires of resistance R_1 and R_2 have temperature co-efficient of resistance α_1 and α_2 respectively. These are joined in series. The effective temperature co-efficient of resistance is

(a) $\frac{\alpha_1 + \alpha_2}{2}$

(b) $\sqrt{\alpha_1 \alpha_2}$

(c) $\frac{\alpha_1 R_1 + \alpha_2 R_2}{R_1 + R_2}$

(d) $\frac{\sqrt{R_1 R_2 \alpha_1 \alpha_2}}{\sqrt{R_1^2 + R_2^2}}$

Solution : (c) Suppose at $t^\circ\text{C}$ resistances of the two wires becomes R_{1t} and R_{2t} respectively and equivalent resistance becomes R_t . In series grouping $R_t = R_{1t} + R_{2t}$, also $R_{1t} = R_1(1 + \alpha_1 t)$ and $R_{2t} = R_2(1 + \alpha_2 t)$

$$R_t = R_1(1 + \alpha_1 t) + R_2(1 + \alpha_2 t) = (R_1 + R_2) + (R_1 \alpha_1 + R_2 \alpha_2)t = (R_1 + R_2) \left[1 + \frac{R_1 \alpha_1 + R_2 \alpha_2}{R_1 + R_2} t \right].$$

Hence effective temperature co-efficient is $\frac{R_1 \alpha_1 + R_2 \alpha_2}{R_1 + R_2}$.

Example: 13 From the graph between current i & voltage V shown, identify the portion corresponding to negative resistance

(a) DE

(b) CD

(c) BC

(d) AB

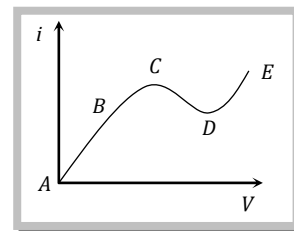

Solution : (b) $R = \frac{\Delta V}{\Delta I}$, in the graph CD has only negative slope. So in this portion R is negative.

Example: 14 A wire of length L and resistance R is stretched to get the radius of cross-section halved. What is new resistance

(a) $5R$

(b) $8R$

(c) $4R$

(d) $16R$

Solution : (d) By using $\frac{R_1}{R_2} = \left(\frac{r_2}{r_1}\right)^4 \Rightarrow \frac{R}{R'} = \left(\frac{r/2}{r}\right)^4 \Rightarrow R' = 16R$

Example: 15 The V - i graph for a conductor at temperature T_1 and T_2 are as shown in the figure. $(T_2 - T_1)$ is proportional to

(a) $\cos 2\theta$

(b) $\sin\theta$

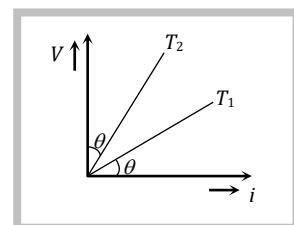

(c) $\cot 2\theta$

(d) $\tan \theta$

Solution : (c) As we know, for conductors resistance \propto Temperature.

From figure $R_1 \propto T_1 \Rightarrow \tan \theta \propto T_1 \Rightarrow \tan \theta = kT_1$ (i) ($k = \text{constant}$)

and $R_2 \propto T_2 \Rightarrow \tan (90^\circ - \theta) \propto T_2 \Rightarrow \cot \theta = kT_2$ (ii)

From equation (i) and (ii) $k(T_2 - T_1) = (\cot \theta - \tan \theta)$

$$(T_2 - T_1) = \left(\frac{\cos \theta}{\sin \theta} - \frac{\sin \theta}{\cos \theta} \right) = \frac{(\cos^2 \theta - \sin^2 \theta)}{\sin \theta \cos \theta} = \frac{\cos 2\theta}{\sin \theta \cos \theta} = 2 \cot 2\theta \Rightarrow (T_2 - T_1) \propto \cot 2\theta$$

Example: 16 The resistance of a wire at 20°C is 20Ω and at 500°C is 60Ω . At which temperature resistance will be 25Ω

- (a) 50°C (b) 60°C (c) 70°C (d) 80°C

Solution : (d) By using $\frac{R_1}{R_2} = \frac{(1 + \alpha t_1)}{(1 + \alpha t_2)} \Rightarrow \frac{20}{60} = \frac{1 + 20\alpha}{1 + 500\alpha} \Rightarrow \alpha = \frac{1}{220}$

Again by using the same formula for 20Ω and $25\Omega \Rightarrow \frac{20}{25} = \frac{\left(1 + \frac{1}{220} \times 20\right)}{\left(1 + \frac{1}{220} \times t\right)} \Rightarrow t = 80^\circ\text{C}$

Example: 17 The specific resistance of manganin is $50 \times 10^{-8} \Omega\text{m}$. The resistance of a manganin cube having length 50 cm is

- (a) $10^{-6} \Omega$ (b) $2.5 \times 10^{-5} \Omega$ (c) $10^{-8} \Omega$ (d) $5 \times 10^{-4} \Omega$

Solution : (a) $R = \rho \frac{l}{A} = \frac{50 \times 10^{-8} \times 50 \times 10^{-2}}{(50 \times 10^{-2})^2} = 10^{-6} \Omega$

Example: 18 A rod of certain metal is 1 m long and 0.6 cm in diameter. It's resistance is $3 \times 10^{-3} \Omega$. A disc of the same metal is 1 mm thick and 2 cm in diameter, what is the resistance between it's circular faces.

- (a) $1.35 \times 10^{-6} \Omega$ (b) $2.7 \times 10^{-7} \Omega$ (c) $4.05 \times 10^{-6} \Omega$ (d) $8.1 \times 10^{-6} \Omega$

Solution : (b) By using $R = \rho \frac{l}{A}$; $\frac{R_{\text{disc}}}{R_{\text{rod}}} = \frac{l_{\text{disc}}}{l_{\text{rod}}} \times \frac{A_{\text{rod}}}{A_{\text{disc}}} \Rightarrow \frac{R_{\text{disc}}}{3 \times 10^{-3}} = \frac{10^{-3}}{1} \times \frac{\pi(0.3 \times 10^{-2})^2}{\pi(10^{-2})^2} \Rightarrow R_{\text{disc}} = 2.7 \times 10^{-7} \Omega$.

Example: 19 An aluminium rod of length 3.14 m is of square cross-section $3.14 \times 3.14 \text{ mm}^2$. What should be the radius of 1 m long another rod of same material to have equal resistance

- (a) 2 mm (b) 4 mm (c) 1 mm (d) 6 mm

Solution : (c) By using $R = \rho \frac{l}{A} \Rightarrow l \propto A \Rightarrow \frac{3.14}{1} = \frac{3.14 \times 3.14 \times 10^{-6}}{\pi \times r^2} \Rightarrow r = 10^{-3} \text{ m} = 1 \text{ mm}$

Example: 20 Length of a hollow tube is 5 m , it's outer diameter is 10 cm and thickness of it's wall is 5 mm . If resistivity of the material of the tube is $1.7 \times 10^{-8} \Omega \times \text{m}$ then resistance of tube will be

- (a) $5.6 \times 10^{-5} \Omega$ (b) $2 \times 10^{-5} \Omega$ (c) $4 \times 10^{-5} \Omega$ (d) None of these

Solution : (a) By using $R = \rho \frac{l}{A}$; here $A = \pi(r_2^2 - r_1^2)$

Outer radius $r_2 = 5 \text{ cm}$

Inner radius $r_1 = 5 - 0.5 = 4.5 \text{ cm}$

$$\text{So } R = 1.7 \times 10^{-8} \times \frac{5}{\pi\{(5 \times 10^{-2})^2 - (4.5 \times 10^{-2})^2\}} = 5.6 \times 10^{-5} \Omega$$

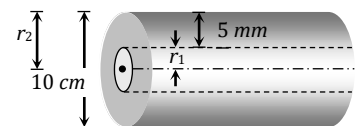

Example: 21 If a copper wire is stretched to make it 0.1% longer, the percentage increase in resistance will be
 (a) 0.2 (b) 2 (c) 1 (d) 0.1

Solution: (a) In case of stretching $R \propto l^2$ So $\frac{\Delta R}{R} = 2 \frac{\Delta l}{l} = 2 \times 0.1 = 0.2$

Example: 22 The temperature co-efficient of resistance of a wire is $0.00125/^\circ C$. At 300 K. It's resistance is 1Ω . The resistance of the wire will be 2Ω at

- (a) 1154 K (b) 1127 K (c) 600 K (d) 1400 K

Solution: (b) By using $R_t = R_0 (1 + \alpha \Delta t) \Rightarrow \frac{R_1}{R_2} = \frac{1 + \alpha t_1}{1 + \alpha t_2}$ So $\frac{1}{2} = \frac{1 + (300 - 273)\alpha}{1 + \alpha t_2} \Rightarrow t_2 = 854^\circ C = 1127 K$

Example: 23 Equal potentials are applied on an iron and copper wire of same length. In order to have same current flow in the wire, the ratio $\left(\frac{r_{iron}}{r_{copper}}\right)$ of their radii must be [Given that specific resistance of iron = $1.0 \times 10^{-7} \Omega m$ and that of copper = $1.7 \times 10^{-8} \Omega m$]

- (a) About 1.2 (b) About 2.4 (c) About 3.6 (d) About 4.8

Solution: (b) $V = \text{constant}, i = \text{constant}$. So $R = \text{constant}$

$$\Rightarrow \frac{P_i l_i}{A_i} = \frac{\rho_{Cu} l_{Cu}}{A_{Cu}} \Rightarrow \frac{\rho_i l_i}{r_i^2} = \frac{\rho_{Cu} l_{Cu}}{r_{Cu}^2}$$

$$\Rightarrow \frac{r_i}{r_{Cu}} = \sqrt{\frac{\rho_i}{\rho_{Cu}}} = \sqrt{\frac{1.0 \times 10^{-7}}{1.7 \times 10^{-8}}} = \sqrt{\frac{100}{17}} \approx 2.4$$

Example: 24 Masses of three wires are in the ratio 1 : 3 : 5 and their lengths are in the ratio 5 : 3 : 1. The ratio of their electrical resistance is

- (a) 1 : 3 : 5 (b) 5 : 3 : 1 (c) 1 : 15 : 125 (d) 125 : 15 : 1

Solution: (d) $R = \rho \frac{l}{A} = \rho \frac{l^2}{V} = \rho \frac{l^2}{m} \sigma \quad \left(\because \sigma = \frac{m}{V}\right)$

$$R_1 : R_2 : R_3 = \frac{l_1^2}{m_1} : \frac{l_2^2}{m_2} : \frac{l_3^2}{m_3} = 25 : \frac{9}{3} : \frac{1}{5} = 125 : 15 : 1$$

Example: 25 Following figure shows cross-sections through three long conductors of the same length and material, with square cross-section of edge lengths as shown. Conductor B will fit snugly within conductor A, and conductor C will fit snugly within conductor B. Relationship between their end to end resistance is

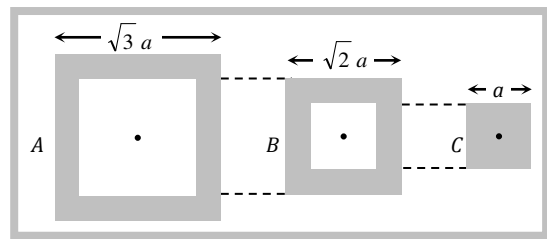

- (a) $R_A = R_B = R_C$
 (b) $R_A > R_B > R_C$
 (c) $R_A < R_B < R$
 (d) Information is not sufficient

Solution: (a) All the conductors have equal lengths. Area of cross-section of A is $\{(\sqrt{3} a)^2 - (\sqrt{2} a)^2\} = a^2$

Similarly area of cross-section of B = Area of cross-section of C = a^2

Hence according to formula $R = \rho \frac{l}{A}$; resistances of all the conductors are equal i.e. $R_A = R_B = R_C$

Example: 26 Dimensions of a block are $1\text{ cm} \times 1\text{ cm} \times 100\text{ cm}$. If specific resistance of its material is $3 \times 10^{-7}\text{ ohm-m}$, then the resistance between its opposite rectangular faces is

- (a) $3 \times 10^{-9}\text{ ohm}$ (b) $3 \times 10^{-7}\text{ ohm}$ (c) $3 \times 10^{-5}\text{ ohm}$ (d) $3 \times 10^{-3}\text{ ohm}$

Solution: (b) Length $l = 1\text{ cm} = 10^{-2}\text{ m}$

Area of cross-section $A = 1\text{ cm} \times 100\text{ cm}$

$$= 100\text{ cm}^2 = 10^{-2}\text{ m}^2$$

$$\text{Resistance } R = 3 \times 10^{-7} \times \frac{10^{-2}}{10^{-2}} = 3 \times 10^{-7}\ \Omega$$

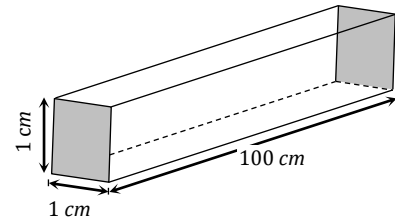

□ In the above question for calculating equivalent resistance between two opposite square faces.

$$l = 100\text{ cm} = 1\text{ m}, A = 1\text{ cm}^2 = 10^{-4}\text{ m}^2, \text{ so resistance } R = 3 \times 10^{-7} \times \frac{1}{10^{-4}} = 3 \times 10^{-3}\ \Omega$$

Example: 3

Two rods A and B of same material and length have their electric resistances are in ratio $1 : 2$. When both the rods are dipped in water, the correct statement will be

- (a) A has more loss of weight (b) B has more loss of weight
(c) Both have same loss of weight (d) Loss of weight will be in the ratio $1 : 2$

Solution: (a) $R = \rho \frac{L}{A} \Rightarrow \frac{R_1}{R_2} = \frac{A_2}{A_1}$ (ρ, L constant) $\Rightarrow \frac{A_1}{A_2} = \frac{R_2}{R_1} = 2$

Now when a body dipped in water, loss of weight = $V\sigma_w g = AL\sigma_w g$

So $\frac{(\text{Loss of weight})_1}{(\text{Loss of weight})_2} = \frac{A_1}{A_2} = 2$; So A has more loss of weight

Example: 3

The $V-i$ graph for a conductor makes an angle θ with V -axis. Here V denotes the voltage and i denotes current. The resistance of conductor is given by

- (a) $\sin\theta$ (b) $\cos\theta$ (c) $\tan\theta$ (d) $\cot\theta$

Solution: (d) At an instant approach the student will choose $\tan\theta$ will be the right answer. But it is to be seen here the curve makes the angle θ with the V -axis. So it makes an angle $(90 - \theta)$ with the i -axis. So resistance = slope = $\tan(90 - \theta) = \cot\theta$.

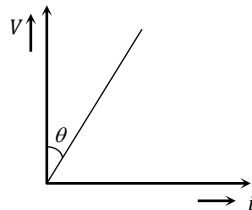

Colour Coding of Resistance.

The resistance, having high values are used in different electrical and electronic circuits. They are generally made up of carbon, like $1\text{ k}\Omega$, $2\text{ k}\Omega$, $5\text{ k}\Omega$ etc. To know the value of resistance colour code is used. These code are

printed in form of set of rings or strips. By reading the values of colour bands, we can estimate the value of resistance.

The carbon resistance has normally four coloured rings or strips say *A*, *B*, *C* and *D* as shown in following figure.

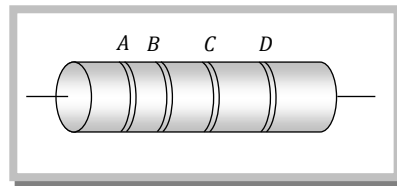

Colour band *A* and *B* indicate the first two significant figures of resistance in *ohm*, while the *C* band gives the decimal multiplier *i.e.* the number of zeros that follows the two significant figures *A* and *B*.

Last band (*D* band) indicates the tolerance in percent about the indicated value or in other ward it represents the percentage accuracy of the indicated value.

The tolerance in the case of gold is $\pm 5\%$ and in silver is $\pm 10\%$. If only three bands are marked on carbon resistance, then it indicate a tolerance of 20%.

The following table gives the colour code for carbon resistance.

Letters as an aid to memory	Colour	Figure (A, B)	Multiplier (C)	Colour	Tolerance (D)
B	Black	0	10^0	Gold	5%
B	Brown	1	10^1	Silver	10%
R	Red	2	10^2	No-colour	20%
O	Orange	3	10^3		
Y	Yellow	4	10^4		
G	Green	5	10^5		
B	Blue	6	10^6		
V	Violet	7	10^7		
G	Grey	8	10^8		
W	White	9	10^9		

☐ To remember the sequence of colour code following sentence should kept in memory.

B B R O Y Great Britain Very Good Wife.

Grouping of Resistance

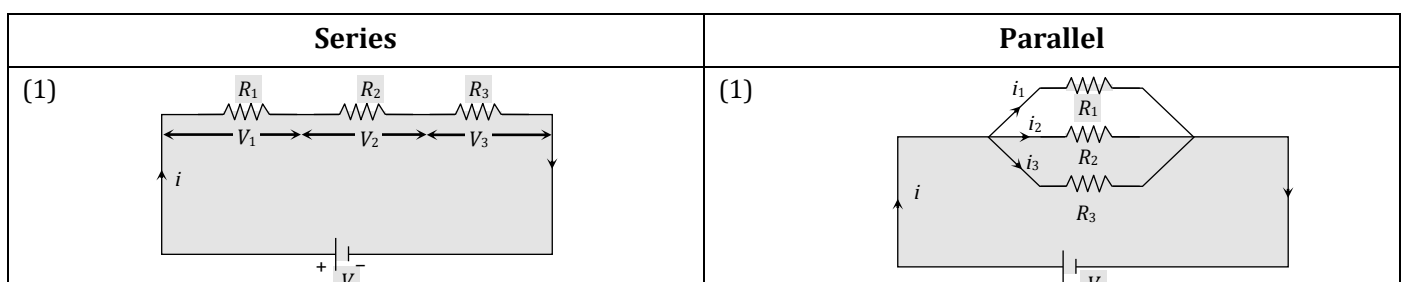

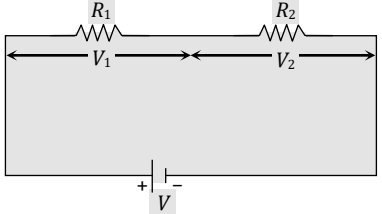
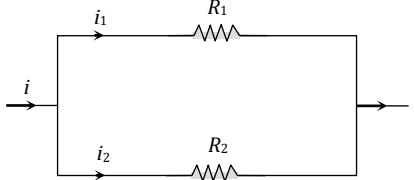
<p>(2) Same current flows through each resistance but potential difference distributes in the ratio of resistance <i>i.e.</i> $V \propto R$</p> <p>Power consumed are in the ratio of their resistance <i>i.e.</i> $P \propto R \Rightarrow P_1 : P_2 : P_3 = R_1 : R_2 : R_3$</p>	<p>(2) Same potential difference appeared across each resistance but current distributes in the reverse ratio of their resistance <i>i.e.</i> $i \propto \frac{1}{R}$</p> <p>Power consumed are in the reverse ratio of resistance <i>i.e.</i> $P \propto \frac{1}{R} \Rightarrow P_1 : P_2 : P_3 = \frac{1}{R_1} : \frac{1}{R_2} : \frac{1}{R_3}$</p>
<p>(3) $R_{eq} = R_1 + R_2 + R_3$ equivalent resistance is greater than the maximum value of resistance in the combination.</p>	<p>(3) $\frac{1}{R_{eq}} = \frac{1}{R_1} + \frac{1}{R_2} + \frac{1}{R_3}$ or $R_{eq} = (R_1^{-1} + R_2^{-1} + R_3^{-1})^{-1}$</p> <p>or $R_{eq} = \frac{R_1 R_2 R_3}{R_1 R_2 + R_2 R_3 + R_3 R_1}$ equivalent resistance is smaller than the minimum value of resistance in the combination.</p>
<p>(4) For two resistance in series $R_{eq} = R_1 + R_2$</p>	<p>(4) For two resistance in parallel $R_{eq} = \frac{R_1 R_2}{R_1 + R_2} = \frac{\text{Multiplication}}{\text{Addition}}$</p>
<p>(5) Potential difference across any resistance $V' = \left(\frac{R'}{R_{eq}} \right) \cdot V$</p> <p>Where $R' =$ Resistance across which potential difference is to be calculated, $R_{eq} =$ equivalent resistance of that line in which R' is connected, $V =$ p.d. across that line in which R' is connected</p> <p><i>e.g.</i></p>  <p>$V_1 = \left(\frac{R_1}{R_1 + R_2} \right) \cdot V$ and $V_2 = \left(\frac{R_2}{R_1 + R_2} \right) \cdot V$</p>	<p>(5) Current through any resistance $i' = i \times \left[\frac{\text{Resistance of opposite branch}}{\text{Total resistance}} \right]$</p> <p>Where $i' =$ required current (branch current) $i =$ main current</p>  <p>$i_1 = i \left(\frac{R_2}{R_1 + R_2} \right)$ and $i_2 = i \left(\frac{R_1}{R_1 + R_2} \right)$</p>
<p>(6) If n identical resistance are connected in series $R_{eq} = nR$ and p.d. across each resistance $V' = \frac{V}{n}$</p>	<p>(6) If n identical resistance are connected in parallel $R_{eq} = \frac{R}{n}$ and current through each resistance $i' = \frac{i}{n}$</p>

- ❑ In case of resistances in series, if one resistance gets open, the current in the whole circuit become zero and the circuit stops working. Which don't happen in case of parallel grouping.
- ❑ Decoration of lightning in festivals is an example of series grouping whereas all household appliances connected in parallel grouping.
- ❑ Using n conductors of equal resistance, the number of possible combinations is $2^n - 1$.
- ❑ If the resistance of n conductors are totally different, then the number of possible combinations will be 2^n .

Methods of Determining Equivalent Resistance For Some Difficult Networks.

(1) **Method of successive reduction** : It is the most common technique to determine the equivalent resistance. So far, we have been using this method to find out the equivalent resistances. This method is

applicable only when we are able to identify resistances in series or in parallel. The method is based on the simplification of the circuit by successive reduction of the series and parallel combinations. For example to calculate the equivalent resistance between the point A and B , the network shown below successively reduced.

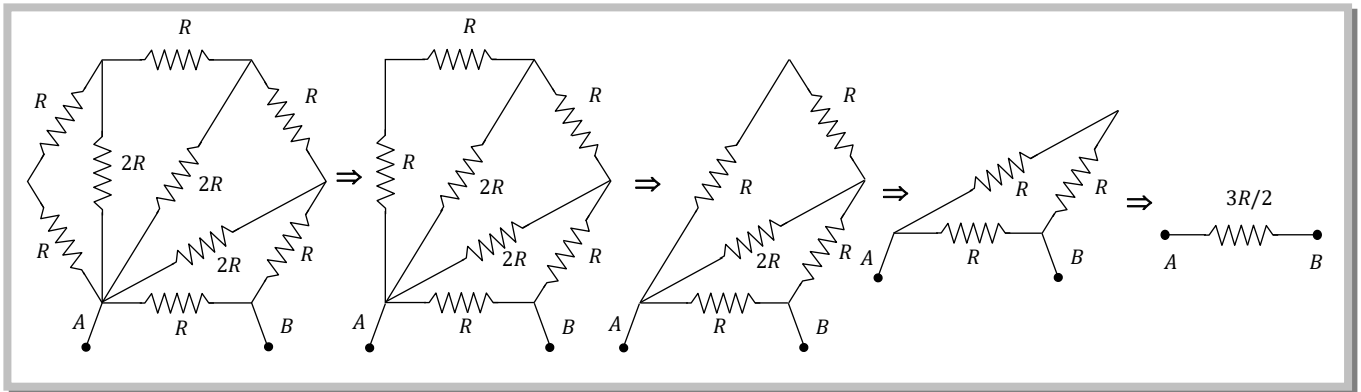

(2) **Method of equipotential points** : This method is based on identifying the points of same potential and joining them. The basic rule to identify the points of same potential is the symmetry of the network.

(i) In a given network there may be two axes of symmetry.

(a) Parallel axis of symmetry, that is, along the direction of current flow.

(b) Perpendicular axis of symmetry, that is perpendicular to the direction of flow of current.

For example in the network shown below the axis AA' is the parallel axis of symmetry, and the axis BB' is the perpendicular axis of symmetry.

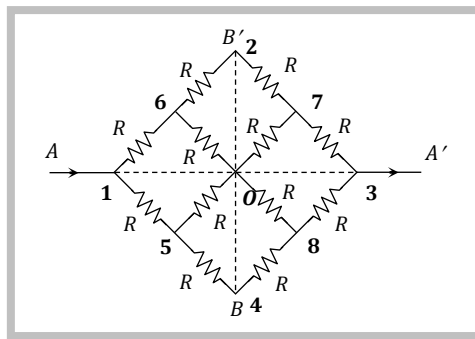

(ii) Points lying on the perpendicular axis of symmetry may have same potential. In the given network, point 2, 0 and 4 are at the same potential.

(iii) Points lying on the parallel axis of symmetry can never have same potential.

(iv) The network can be folded about the parallel axis of symmetry, and the overlapping nodes have same potential. Thus as shown in figure, the following points have same potential

(a) 5 and 6

(b) 2, 0 and 4

(c) 7 and 8

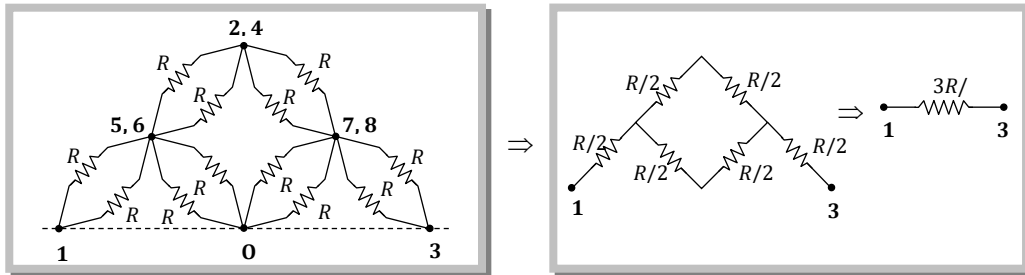

□ Above network may be split up into two equal parts about the parallel axis of symmetry as shown in figure each part has a resistance R' , then the equivalent resistance of the network will be $R = \frac{R'}{2}$.

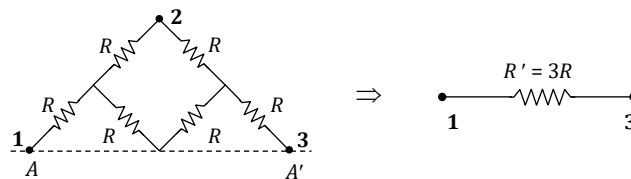

Some Standard Results for Equivalent Resistance.

(1) Equivalent resistance between points A and B in an unbalanced Wheatstone's bridge as shown in the diagram.

(i)

$$R_{AB} = \frac{PQ(R+S) + (P+Q)RS + G(P+Q)(R+S)}{G(P+Q+R+S) + (P+R)(Q+S)}$$

(ii)

$$R_{AB} = \frac{2PQ + G(P+Q)}{2G + P+Q}$$

(2) A cube each side have resistance R then equivalent resistance in different situations

(i) Between E and C i.e. across the diagonal of the cube $R_{EC} = \frac{5}{6} R$

(ii) Between A and B i.e. across one side of the cube $R_{AB} = \frac{7}{12} R$

(iii) Between A and C i.e. across the diagonal of one face of the cube $R_{AC} = \frac{3}{4} R$

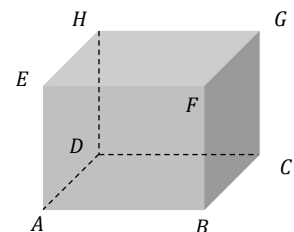

(3) The equivalent resistance of infinite network of resistances

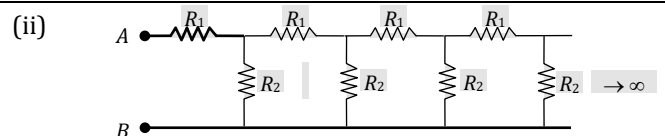
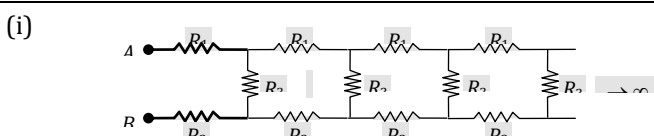

$$R_{AB} = \frac{1}{2}(R_1 + R_2) + \frac{1}{2}[(R_1 + R_2)^2 + 4R_3(R_1 + R_2)]^{1/2}$$

$$R_{AB} = \frac{1}{2}R_1 \left[1 + \sqrt{1 + 4\left(\frac{R_2}{R_1}\right)} \right]$$

Concepts

☞ If n identical resistances are first connected in series and then in parallel, the ratio of the equivalent resistance is given by

$$\frac{R_p}{R_s} = \frac{n^2}{1}$$

☞ If equivalent resistance of R_1 and R_2 in series and parallel be R_s and R_p respectively then $R_1 = \frac{1}{2} \left[R_s + \sqrt{R_s^2 - 4R_s R_p} \right]$ and

$$R_2 = \frac{1}{2} \left[R_s - \sqrt{R_s^2 - 4R_s R_p} \right]$$

☞ If a wire of resistance R , cut in n equal parts and then these parts are collected to form a bundle then equivalent resistance of combination will be $\frac{R}{n^2}$.

Example

Example: 27 In the figure a carbon resistor has band of different colours on its body. The resistance of the following body is

- (a) 2.2 k Ω
- (b) 3.3 k Ω
- (c) 5.6 k Ω
- (d) 9.1 k Ω

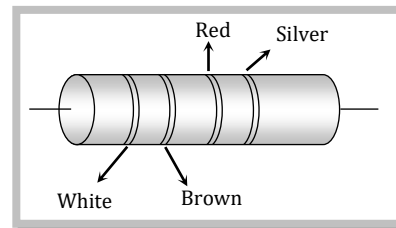

Solution : (d) $R = 91 \times 10^2 \pm 10\% \approx 9.1 \text{ k}\Omega$

Example: 28 What is the resistance of a carbon resistance which has bands of colours brown, black and brown

- (a) 100 Ω
- (b) 1000 Ω
- (c) 10 Ω
- (d) 1 Ω

Solution : (a) $R = 10 \times 10^1 \pm 20\% \approx 100 \Omega$

Example: 29 In the following circuit reading of voltmeter V is

- (a) 12 V
- (b) 8 V
- (c) 20 V
- (d) 16 V

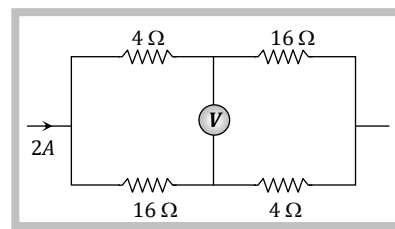

Solution : (a) P.d. between X and Y is $V_{XY} = V_X - V_Y = 1 \times 4 = 4 \text{ V}$ (i)

and p.d. between X and Z is $V_{XZ} = V_X - V_Z = 1 \times 16 = 16 \text{ V}$ (ii)

On solving equations (i) and (ii) we get potential difference between Y and Z i.e., reading of voltmeter is $V_Y - V_Z = 12 \text{ V}$

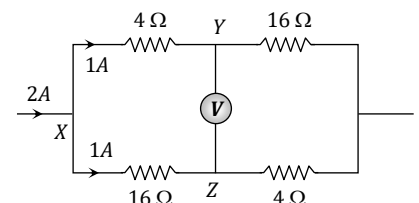

Example: 30 An electric cable contains a single copper wire of radius 9 mm. Its resistance is 5 Ω. This cable is replaced by six insulated copper wires, each of radius 3 mm. The resultant resistance of cable will be

- (a) 7.5 Ω (b) 45 Ω (c) 90 Ω (d) 270 Ω

Solution : (a) Initially : Resistance of given cable

$$R = \rho \frac{l}{\pi \times (9 \times 10^{-3})^2} \quad \dots (i)$$

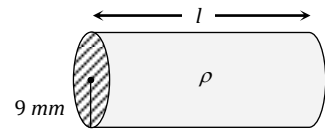

Finally : Resistance of each insulated copper wire is

$$R' = \rho \frac{l}{\pi \times (3 \times 10^{-3})^2}$$

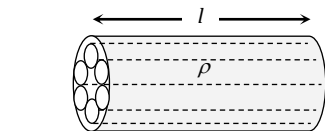

Hence equivalent resistance of cable

$$R_{eq} = \frac{R'}{6} = \frac{1}{6} \times \left(\rho \frac{l}{\pi \times (3 \times 10^{-3})^2} \right) \quad \dots (ii)$$

On solving equation (i) and (ii) we get $R_{eq} = 7.5 \Omega$

Example: 31 Two resistance R_1 and R_2 provides series to parallel equivalents as $\frac{n}{1}$ then the correct relationship is

- (a) $\left(\frac{R_1}{R_2}\right)^2 + \left(\frac{R_2}{R_1}\right)^2 = n^2$ (b) $\left(\frac{R_1}{R_2}\right)^{3/2} + \left(\frac{R_2}{R_1}\right)^{3/2} = n^{3/2}$
 (c) $\left(\frac{R_1}{R_2}\right) + \left(\frac{R_2}{R_1}\right) = n$ (d) $\left(\frac{R_1}{R_2}\right)^{1/2} + \left(\frac{R_2}{R_1}\right)^{1/2} = n^{1/2}$

Solution : (d) Series resistance $R_s = R_1 + R_2$ and parallel resistance $R_p = \frac{R_1 R_2}{R_1 + R_2} \Rightarrow \frac{R_s}{R_p} = \frac{(R_1 + R_2)^2}{R_1 R_2} = n$

$$\Rightarrow \frac{R_1 + R_2}{\sqrt{R_1 R_2}} = \sqrt{n} \quad \Rightarrow \frac{\sqrt{R_1^2} + \sqrt{R_2^2}}{\sqrt{R_1 R_2}} = \sqrt{n} \Rightarrow \sqrt{\frac{R_1}{R_2}} + \sqrt{\frac{R_2}{R_1}} = \sqrt{n}$$

Example: 32 Five resistances are combined according to the figure. The equivalent resistance between the point X and Y will be

- (a) 10 Ω
 (b) 22 Ω
 (c) 20 Ω
 (d) 50 Ω

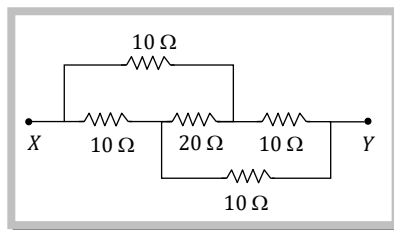

Solution : (a) The equivalent circuit of above can be drawn as

Which is a balanced wheatstone bridge.

So current through AB is zero.

$$\text{So } \frac{1}{R} = \frac{1}{20} + \frac{1}{20} = \frac{1}{10} \Rightarrow R = 10 \Omega$$

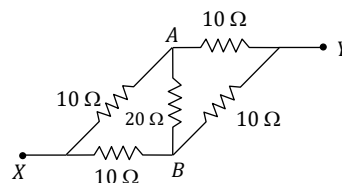

Example: 33 What will be the equivalent resistance of circuit shown in figure between points A and D

- (a) $10\ \Omega$
- (b) $20\ \Omega$
- (c) $30\ \Omega$
- (d) $40\ \Omega$

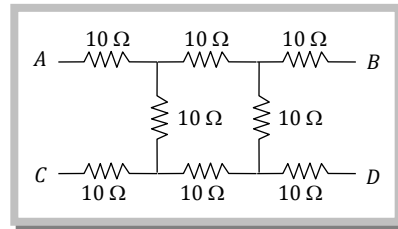

Solution : (c)

The equivalent circuit of above fig between A and D can be drawn as

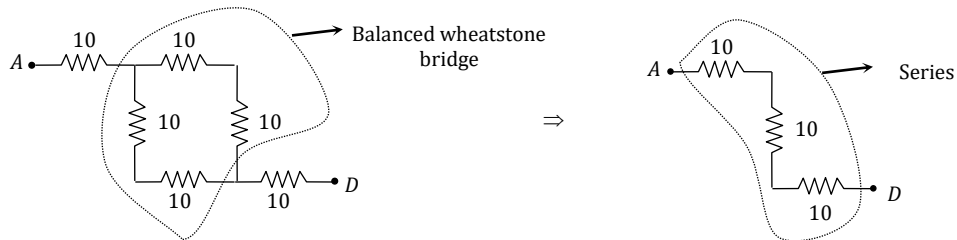

So $R_{eq} = 10 + 10 + 10 = 30\ \Omega$

Example: 34

In the network shown in the figure each of resistance is equal to $2\ \Omega$. The resistance between A and B is

- (a) $1\ \Omega$
- (b) $2\ \Omega$
- (c) $3\ \Omega$
- (d) $4\ \Omega$

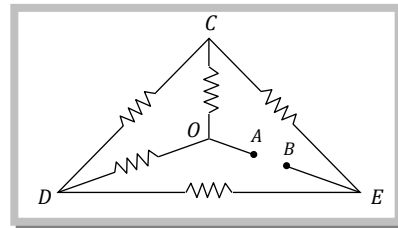

Solution : (b)

Taking the portion COD is figure to outside the triangle (left), the above circuit will be now as resistance of each is $2\ \Omega$ the circuit will behaves as a balanced wheatstone bridge and no current flows through CD. Hence $R_{AB} = 2\ \Omega$

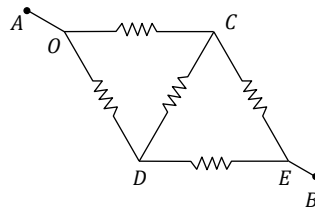

Example: 35

Seven resistances are connected as shown in figure. The equivalent resistance between A and B is

- (a) $3\ \Omega$
- (b) $4\ \Omega$
- (c) $4.5\ \Omega$
- (d) $5\ \Omega$

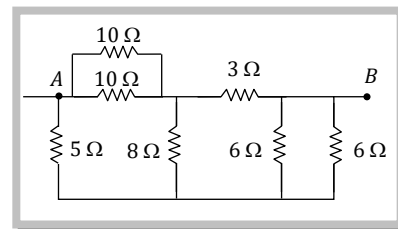

Solution : (b)

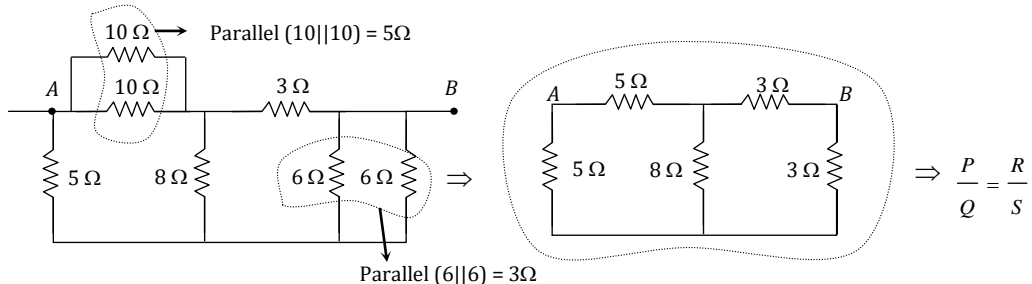

So the circuit is a balanced wheatstone bridge.

So current through $8\ \Omega$ is zero $R_{eq} = (5 + 3) || (5 + 3) = 8 || 8 = 4\ \Omega$

Example: 36

The equivalent resistance between points *A* and *B* of an infinite network of resistance, each of $1\ \Omega$, connected as shown is

- (a) Infinite
- (b) $2\ \Omega$
- (c) $\frac{1 + \sqrt{5}}{2}\ \Omega$
- (d) Zero

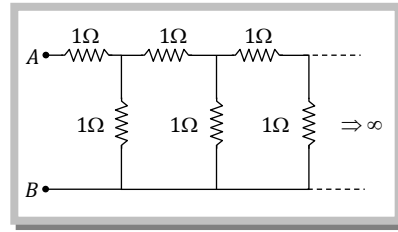

Solution : (c)

Suppose the effective resistance between *A* and *B* is R_{eq} . Since the network consists of infinite cell. If we exclude one cell from the chain, remaining network have infinite cells *i.e.* effective resistance between *C* and *D* will also R_{eq}

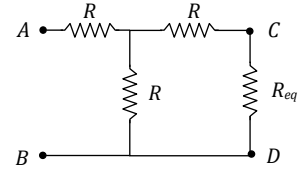

$$\text{So now } R_{eq} = R_o + (R || R_{eq}) = R + \frac{R R_{eq}}{R + R_{eq}} \Rightarrow R_{eq} = \frac{1}{2} [1 + \sqrt{5}]$$

Example: 37

Four resistances $10\ \Omega$, $5\ \Omega$, $7\ \Omega$ and $3\ \Omega$ are connected so that they form the sides of a rectangle *AB*, *BC*, *CD* and *DA* respectively. Another resistance of $10\ \Omega$ is connected across the diagonal *AC*. The equivalent resistance between *A* & *B* is

- (a) $2\ \Omega$
- (b) $5\ \Omega$
- (c) $7\ \Omega$
- (d) $10\ \Omega$

Solution : (b)

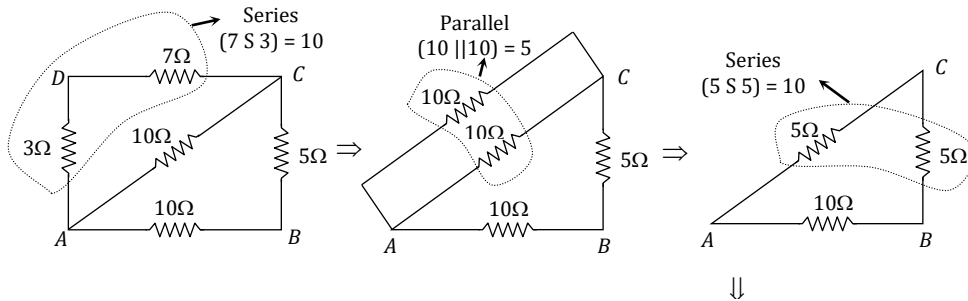

So
$$R_{eq} = \frac{10 \times 10}{10 + 10} = 5\ \Omega$$

Example: 38

The equivalent resistance between *A* and *B* in the circuit shown will be

- (a) $\frac{5}{4}r$
- (b) $\frac{6}{5}r$
- (c) $\frac{7}{6}r$
- (d) $\frac{8}{7}r$

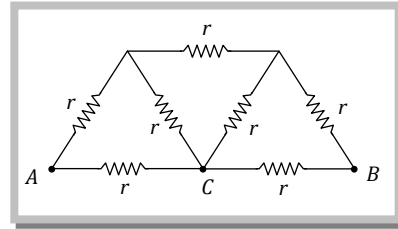

Solution : (d) In the circuit, by means of symmetry the point C is at zero potential. So the equivalent circuit can be drawn as

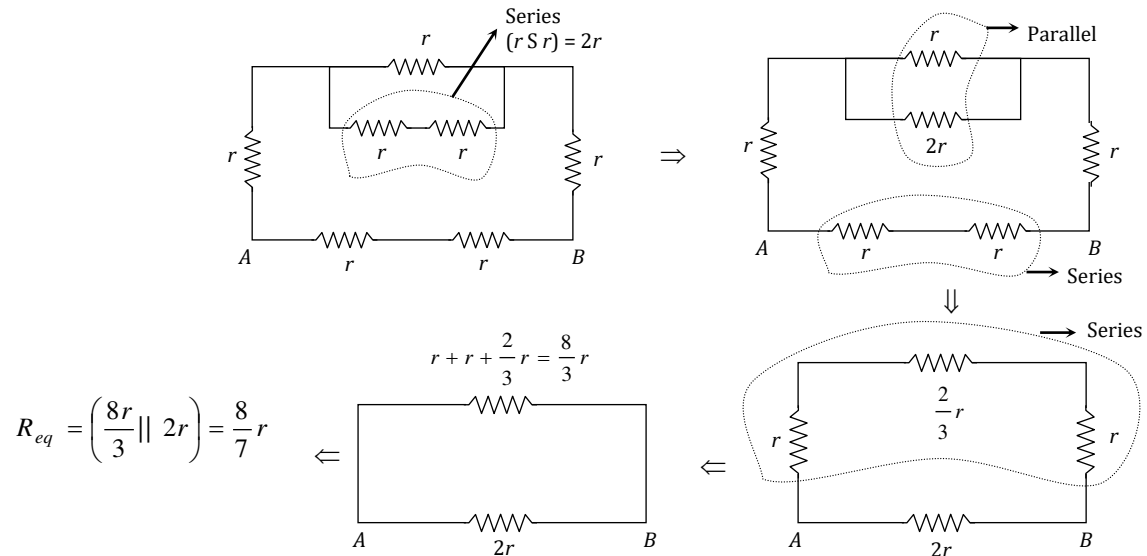

Example: 39 In the given figure, equivalent resistance between A and B will be

- (a) $\frac{14}{3} \Omega$
- (b) $\frac{3}{14} \Omega$
- (c) $\frac{9}{14} \Omega$
- (d) $\frac{14}{9} \Omega$

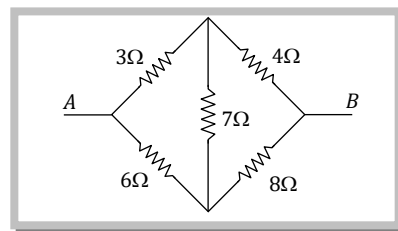

Solution : (a) Given Wheatstone bridge is balanced because $\frac{P}{Q} = \frac{R}{S}$. Hence the circuit can be redrawn as follows

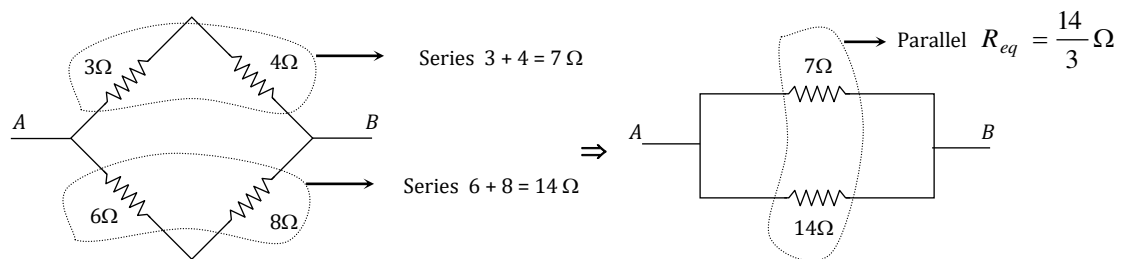

Example: 40 In the combination of resistances shown in the figure the potential difference between B and D is zero, when unknown resistance (x) is

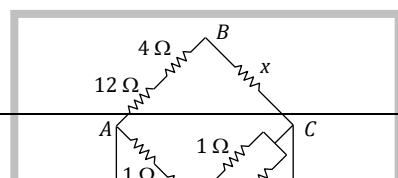

- (a) 4Ω
- (b) 2Ω
- (c) 3Ω
- (d) The emf of the cell is required

Solution : (b) The potential difference across B, D will be zero, when the circuit will act as a balanced wheatstone bridge and $\frac{P}{Q} = \frac{R}{S} \Rightarrow \frac{12 + 4}{x} = \frac{1 + 3}{1/2} \Rightarrow x = 2\Omega$

Example: 41 A current of $2 A$ flows in a system of conductors as shown. The potential difference ($V_A - V_B$) will be

- (a) $+ 2V$
- (b) $+ 1V$
- (c) $- 1 V$
- (d) $- 2 V$

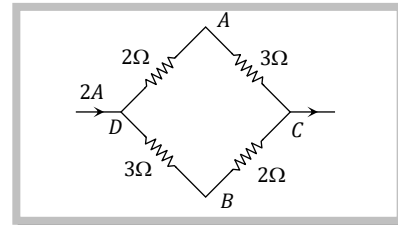

Solution : (b) In the given circuit $2A$ current divides equally at junction D along the paths DAC and DBC (each path carry $1A$ current).
 Potential difference between D and A , $V_D - V_A = 1 \times 2 = 2 \text{ volt}$ (i)
 Potential difference between D and B , $V_D - V_B = 1 \times 3 = 3 \text{ volt}$ (ii)
 On solving (i) and (ii) $V_A - V_B = + 1 \text{ volt}$

Example: 42 Three resistances each of 4Ω are connected in the form of an equilateral triangle. The effective resistance between two corners is

- (a) 8Ω
- (b) 12Ω
- (c) $\frac{3}{8} \Omega$
- (d) $\frac{8}{3} \Omega$

Solution : (d)

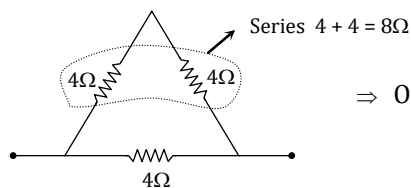

\Rightarrow On Solving further we get equivalent resistance is $\frac{8}{3} \Omega$

Example: 43 If each resistance in the figure is of 9Ω then reading of ammeter is

- (a) $5 A$
- (b) $8 A$
- (c) $2 A$
- (d) $9 A$

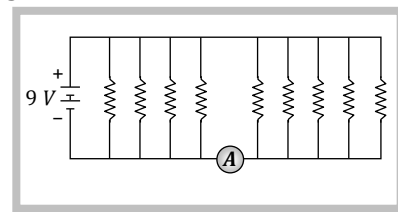

Solution : (a) Main current through the battery $i = \frac{9}{1} = 9A$. Current through each resistance will be $1A$ and only 5 resistances on the right side of ammeter contributes for passing current through the ammeter. So reading of ammeter will be $5A$.

Example: 44 A wire has resistance 12Ω . It is bent in the form of a circle. The effective resistance between the two points on any diameter is equal to

- (a) 12Ω
- (b) 6Ω
- (c) 3Ω
- (d) 24Ω

Solution : (c) Equivalent resistance of the following circuit will be

$$R_{eq} = \frac{6}{2} = 3\Omega$$

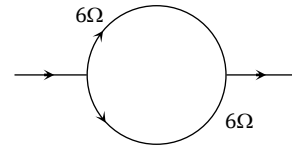

Example: 45 A wire of resistance $0.5 \Omega m^{-1}$ is bent into a circle of radius $1 m$. The same wire is connected across a diameter AB as shown in fig. The equivalent resistance is

- (a) πohm
- (b) $\pi(\pi + 2) ohm$
- (c) $\pi / (\pi + 4) ohm$
- (d) $(\pi + 1) ohm$

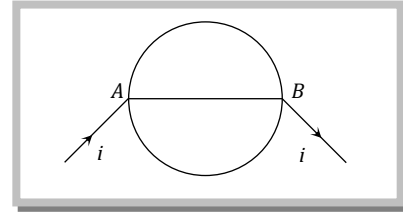

Solution : (c) Resistance of upper semicircle = Resistance of lower semicircle

$$= 0.5 \times (\pi R) = 0.5 \pi \Omega$$

Resistance of wire $AB = 0.5 \times 2 = 1 \Omega$

Hence equivalent resistance between A and B

$$\frac{1}{R_{AB}} = \frac{1}{0.5\pi} + \frac{1}{1} + \frac{1}{0.5\pi} \Rightarrow R_{AB} = \frac{\pi}{(\pi + 4)} \Omega$$

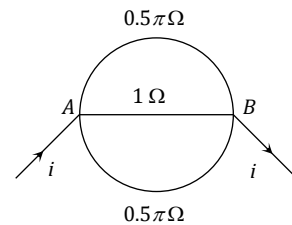

Example: 46 A wire of resistor R is bent into a circular ring of radius r . Equivalent resistance between two points X and Y on its circumference, when angle XOY is α , can be given by

- (a) $\frac{R\alpha}{4\pi^2} (2\pi - \alpha)$
- (b) $\frac{R}{2\pi} (2\pi - \alpha)$
- (c) $R(2\pi - \alpha)$
- (d) $\frac{4\pi}{R\alpha} (2\pi - \alpha)$

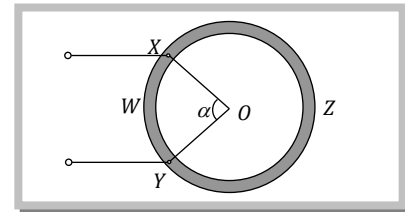

Solution : (a) Here $R_{XWY} = \frac{R}{2\pi r} \times (r\alpha) = \frac{R\alpha}{2\pi}$ ($\because \alpha = \frac{l}{r}$) and $R_{XZY} = \frac{R}{2\pi r} \times r(2\pi - \alpha) = \frac{R}{2\pi} (2\pi - \alpha)$

$$R_{eq} = \frac{R_{XWY} R_{XZY}}{R_{XWY} + R_{XZY}} = \frac{\frac{R\alpha}{2\pi} \times \frac{R}{2\pi} (2\pi - \alpha)}{\frac{R\alpha}{2\pi} + \frac{R(2\pi - \alpha)}{2\pi}} = \frac{R\alpha}{4\pi^2} (2\pi - \alpha)$$

Example: 47 If in the given figure $i = 0.25 amp$, then the value R will be

- (a) 48Ω
- (b) 12Ω
- (c) 120Ω
- (d) 42Ω

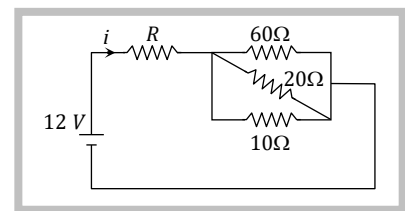

Solution : (d) $i = 0.25 amp$ $V = 12 V$ $R_{eq} = \frac{V}{i} = \frac{12}{0.25} = 48 \Omega$

Now from the circuit $R_{eq} = R + (60 \parallel 20 \parallel 10)$

$$= R + 6$$

$$\Rightarrow R = R_{eq} - 6 = 48 - 6 = 42 \Omega$$

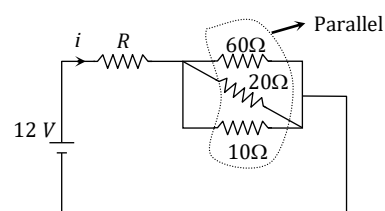

Example: 48 Two uniform wires A and B are of the same metal and have equal masses. The radius of wire A is twice that of wire B . The total resistance of A and B when connected in parallel is

- (a) $4\ \Omega$ when the resistance of wire A is $4.25\ \Omega$ (b) $5\ \Omega$ when the resistance of wire A is $4\ \Omega$
 (c) $4\ \Omega$ when the resistance of wire B is $4.25\ \Omega$ (d) $5\ \Omega$ when the resistance of wire B is $4\ \Omega$

Solution : (a) Density and masses of wire are same so their volumes are same i.e. $A_1 l_1 = A_2 l_2$

$$\text{Ratio of resistances of wires } A \text{ and } B \quad \frac{R_A}{R_B} = \frac{l_1}{l_2} \times \frac{A_2}{A_1} = \left(\frac{A_2}{A_1}\right)^2 = \left(\frac{r_2}{r_1}\right)^4$$

$$\text{Since } r_1 = 2r_2 \text{ so } \frac{R_A}{R_B} = \frac{1}{16} \Rightarrow R_B = 16 R_A$$

Resistance R_A and R_B are connected in parallel so equivalent resistance $R = \frac{R_A R_B}{R_A + R_B} = \frac{16 R_A}{17}$, By checking correctness of equivalent resistance from options, only option (a) is correct.

Example: 5

The effective resistance between point P and Q of the electrical circuit shown in the figure is

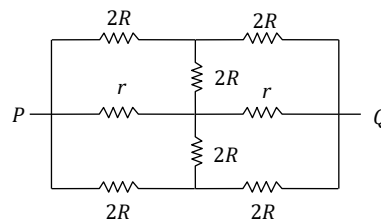

- (a) $\frac{2Rr}{R+r}$ (b) $\frac{8R(R+r)}{3R+r}$ (c) $2r + 4R$ (d) $\frac{5R}{2} + 2r$

Solution : (a) The points A, O, B are at same potential. So the figure can be redrawn as follows

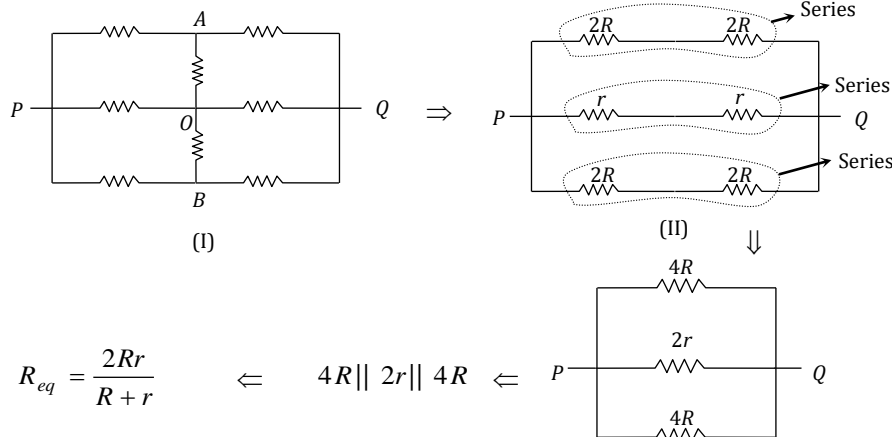

Example: 6

In the following circuit if key K is pressed then the galvanometer reading becomes half. The resistance of galvanometer is

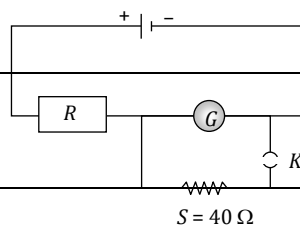

(a) 20Ω

(b) 30Ω

(c) 40Ω

(d) 50Ω

Solution : (c) Galvanometer reading becomes half means current distributes equally between galvanometer and resistance of 40Ω . Hence galvanometer resistance must be 40Ω .

Cell.

The device which converts chemical energy into electrical energy is known as electric cell.

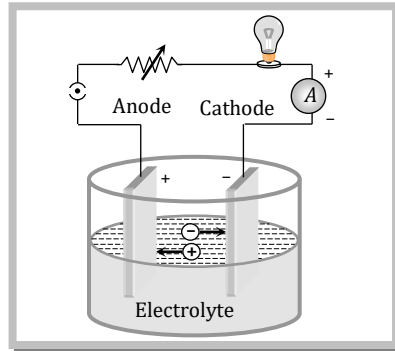

(1) A cell neither creates nor destroys charge but maintains the flow of charge present at various parts of the circuit by supplying energy needed for their organised motion.

(2) Cell is a source of constant emf but not constant current.

(3) Mainly cells are of two types :

(i) Primary cell : Cannot be recharged

(ii) Secondary cell : Can be recharged

(4) The direction of flow of current inside the cell is from negative to positive electrode while outside the cell is from positive to negative electrode.

(5) A cell is said to be ideal, if it has zero internal resistance.

(6) **Emf of cell (E)** : The energy given by the cell in the flow of unit charge in the whole circuit (including the cell) is called its electromotive force (emf) *i.e.* emf of cell $E = \frac{W}{q}$, Its unit is *volt*

or

The potential difference across the terminals of a cell when it is not given any current is called its emf.

(7) **Potential difference (V)** : The energy given by the cell in the flow of unit charge in a specific part of electrical circuit (external part) is called potential difference. Its unit is also *volt*

or

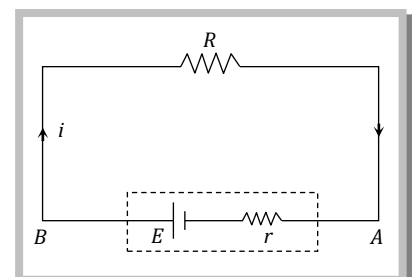

The voltage across the terminals of a cell when it is supplying current to external resistance is called potential difference or terminal voltage. Potential difference is equal to the product of current and resistance of that given part i.e. $V = iR$.

(8) **Internal resistance (r)** : In case of a cell the opposition of electrolyte to the flow of current through it is called internal resistance of the cell. The internal resistance of a cell depends on the distance between electrodes ($r \propto d$), area of electrodes [$r \propto (1/A)$] and nature, concentration ($r \propto C$) and temperature of electrolyte [$r \propto (1/\text{temp.})$]. Internal resistance is different for different types of cells and even for a given type of cell it varies from cell to cell.

Cell in Various Position.

(1) Closed circuit (when the cell is discharging)

(i) Current given by the cell $i = \frac{E}{R + r}$

(ii) Potential difference across the resistance $V = iR$

(iii) Potential drop inside the cell = ir

(iv) Equation of cell $E = V + ir$ ($E > V$)

(v) Internal resistance of the cell $r = \left(\frac{E}{V} - 1 \right) \cdot R$

(vi) Power dissipated in external resistance (load) $P = Vi = i^2 R = \frac{V^2}{R} = \left(\frac{E}{R + r} \right)^2 \cdot R$

Power delivered will be maximum when $R = r$ so $P_{\text{max}} = \frac{E^2}{4r}$.

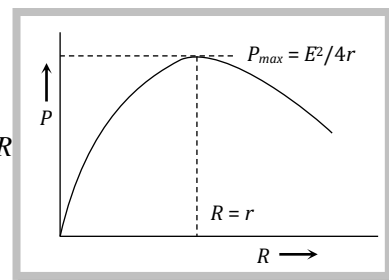
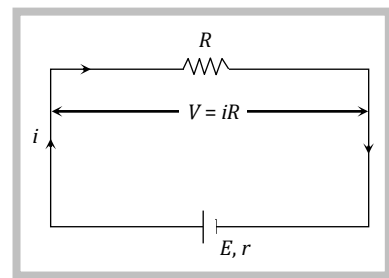

This statement in generalised form is called “maximum power transfer theorem”.

(vii) **Short trick to calculate E and r** : In the closed circuit of a cell having emf E and internal resistance r . If external resistance changes from R_1 to R_2 then current changes from i_1 to i_2 and potential difference changes from V_1 to V_2 . By using following relations we can find the value of E and r .

$$E = \frac{i_1 i_2}{i_2 - i_1} (R_1 - R_2) \quad r = \left(\frac{i_2 R_2 - i_1 R_1}{i_1 - i_2} \right) = \frac{V_2 - V_1}{i_1 - i_2}$$

□ When the cell is charging i.e. current is given to the cell then $E = V - ir$ and $E < V$.

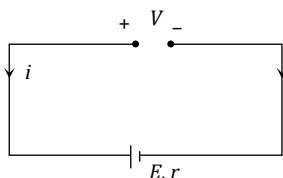

(2) Open circuit and short circuit

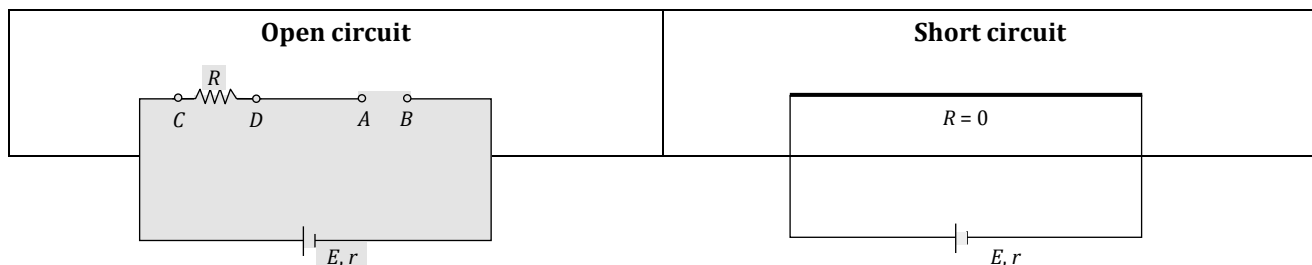

(i) Current through the circuit $i = 0$	(i) Maximum current (called short circuit current) flows momentarily $i_{sc} = \frac{E}{r}$
(ii) Potential difference between A and B, $V_{AB} = E$	(ii) Potential difference $V = 0$
(iii) Potential difference between C and D, $V_{CD} = 0$	

☐ Above information's can be summarized by the following graph

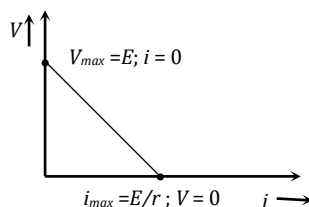

Concepts

☞ *It is a common misconception that "current in the circuit will be maximum when power consumed by the load is maximum."*

Actually current $i = E/(R+r)$ is maximum ($= E/r$) when $R = \text{min} = 0$ with $P_L = (E/r)^2 \times 0 = 0 \text{ min}$. while power consumed by the load $E^2R/(R+r)^2$ is maximum ($= E^2/4r$) when $R = r$ and $i = (E/2r) \neq \text{max}(= E/r)$.

☞ *Emf is independent of the resistance of the circuit and depends upon the nature of electrolyte of the cell while potential difference depends upon the resistance between the two points of the circuit and current flowing through the circuit.*

☞ *Emf is a cause and potential difference is an effect.*

☞ *Whenever a cell or battery is present in a branch there must be some resistance (internal or external or both) present in that branch. In practical situation it always happen because we can never have an ideal cell or battery with zero resistance.*

Example

Example: 49 A new flashlight cell of emf 1.5 volts gives a current of 15 amps, when connected directly to an ammeter of resistance 0.04 Ω . The internal resistance of cell is

- (a) 0.04 Ω (b) 0.06 Ω (c) 0.10 Ω (d) 10 Ω

Solution : (b) By using $i = \frac{E}{R+r} \Rightarrow 15 = \frac{1.5}{0.04+r} \Rightarrow r = 0.06 \Omega$

Example: 50 For a cell, the terminal potential difference is 2.2 V when the circuit is open and reduces to 1.8 V, when the cell is connected across a resistance, $R = 5\Omega$. The internal resistance of the cell is

- (a) $\frac{10}{9} \Omega$ (b) $\frac{9}{10} \Omega$ (c) $\frac{11}{9} \Omega$ (d) $\frac{5}{9} \Omega$

Solution : (a) In open circuit, $E = V = 2.2 V$, In close circuit, $V = 1.8 V, R = 5\Omega$

So internal resistance, $r = \left(\frac{E}{V} - 1\right)R = \left(\frac{2.2}{1.8} - 1\right) \times 5 \Rightarrow r = \frac{10}{9} \Omega$

Example: 51 The internal resistance of a cell of emf 2V is 0.1 Ω . It's connected to a resistance of 3.9 Ω . The voltage across the cell will be

- (a) 0.5 volt (b) 1.9 volt (c) 1.95 volt (d) 2 volt

Solution : (c) By using $r = \left(\frac{E}{V} - 1\right)R \Rightarrow 0.1 = \left(\frac{2}{V} - 1\right) \times 3.9 \Rightarrow V = 1.95 \text{ volt}$

Example: 52 When the resistance of 2 Ω is connected across the terminal of the cell, the current is 0.5 amp. When the resistance is increased to 5 Ω , the current is 0.25 amp. The emf of the cell is

- (a) 1.0 volt (b) 1.5 volt (c) 2.0 volt (d) 2.5 volt

Solution : (b) By using $E = \frac{i_1 i_2}{(i_2 - i_1)}(R_1 - R_2) = \frac{0.5 \times 0.25}{(0.25 - 0.5)}(2 - 5) = 1.5 \text{ volt}$

Example: 53 A primary cell has an emf of 1.5 volts, when short-circuited it gives a current of 3 amperes. The internal resistance of the cell is

- (a) 4.5 ohm (b) 2 ohm (c) 0.5 ohm (d) 1/4.5 ohm

Solution : (c) $i_{sc} = \frac{E}{r} \Rightarrow 3 = \frac{1.5}{r} \Rightarrow r = 0.5 \Omega$

Example: 54 A battery of internal resistance 4 Ω is connected to the network of resistances as shown. In order to give the maximum power to the network, the value of R (in Ω) should be

- (a) 4/9
(b) 8/9
(c) 2
(d) 18

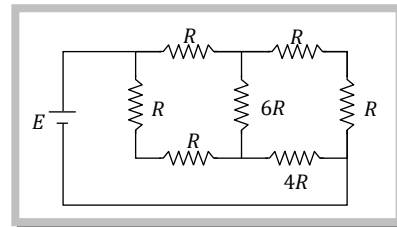

Solution : (c) The equivalent circuit becomes a balanced wheatstone bridge

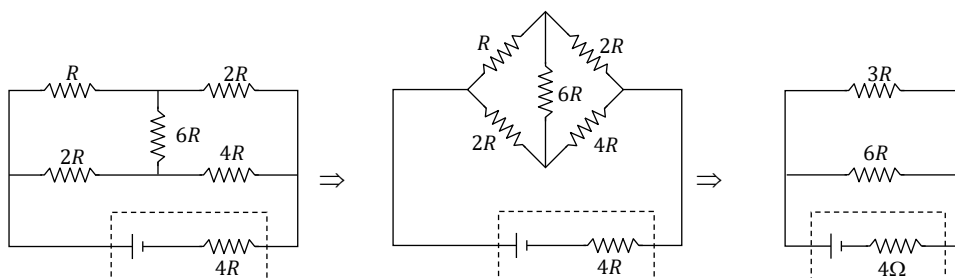

For maximum power transfer, external resistance should be equal to internal resistance of source

$$\Rightarrow \frac{(R + 2R)(2R + 4R)}{(R + 2R) + (2R + 4R)} = 4 \text{ i.e. } \frac{3R \times 6R}{3R + 6R} = 4 \text{ or } R = 2\Omega$$

Example: 55 A torch bulb rated as 4.5 W, 1.5 V is connected as shown in the figure. The emf of the cell needed to make the bulb glow at full intensity is

- (a) 4.5 V
- (b) 1.5 V
- (c) 2.67 V
- (d) 13.5 V

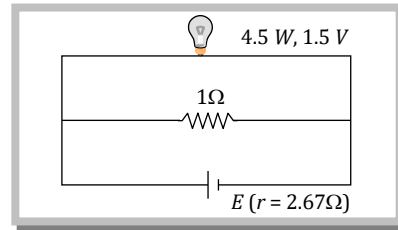

Solution : (d) When bulb glows with full intensity, potential difference across it is 1.5 V. So current through the bulb and resistance of 1Ω are 3 A and 1.5 A respectively. So main current from the cell $i = 3 + 1.5 = 4.5$ A. By using $E = V + iR \Rightarrow E = 1.5 + 4.5 \times 2.67 = 13.5$ V.

Example: 7

Potential difference across the terminals of the battery shown in figure is (r = internal resistance of battery)

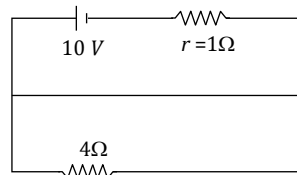

- (a) 8 V
- (b) 10 V
- (c) 6 V
- (d) Zero

Solution : (d) Battery is short circuited so potential difference is zero.

Grouping of cell.

Group of cell is called a battery.

(1) **Series grouping :** In series grouping anode of one cell is connected to cathode of other cell and so on.

(i) **n identical cells are connected in series**

(a) Equivalent emf of the combination $E_{eq} = nE$

(b) Equivalent internal resistance $r_{eq} = nr$

(c) Main current = Current from each cell $= i = \frac{nE}{R + nr}$

(d) Potential difference across external resistance $V = iR$

(e) Potential difference across each cell $V' = \frac{V}{n}$

(f) Power dissipated in the circuit $P = \left(\frac{nE}{R + nr} \right)^2 \cdot R$

(g) Condition for maximum power $R = nr$ and $P_{\max} = n \left(\frac{E^2}{4r} \right)$

(h) This type of combination is used when $nr \ll R$.

(ii) **If non-identical cell are connected in series**

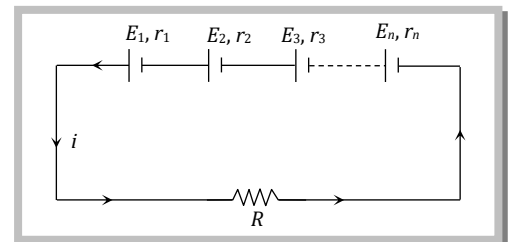

Cells are connected in right order

Cells are wrongly connected

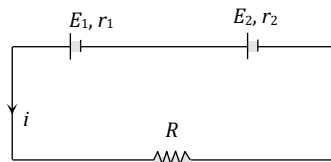

(a) Equivalent emf $E_{eq} = E_1 + E_2$

(b) Current $i = \frac{E_{eq}}{R + r_{eq}}$

(c) Potential difference across each cell $V_1 = E_1 - ir_1$ and $V_2 = E_2 - ir_2$

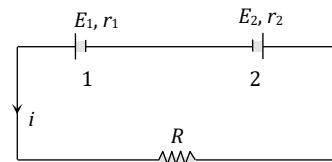

$(E_1 > E_2)$

(a) Equivalent emf $E_{eq} = E_1 - E_2$

(b) Current $i = \frac{E_1 - E_2}{R + r_{eq}}$

(c) in the above circuit cell 1 is discharging so its equation is $E_1 = V_1 + ir_1 \Rightarrow V_1 = E_1 - ir_1$ and cell 2 is charging so its equation

$$E_2 = V_2 - ir_2 \Rightarrow V_2 = E_2 + ir_2$$

(2) **Parallel grouping** : In parallel grouping all anodes are connected at one point and all cathode are connected together at other point.

(i) **If n identical cells are connected in parallel**

(a) Equivalent emf $E_{eq} = E$

(b) Equivalent internal resistance $R_{eq} = r/n$

(c) Main current $i = \frac{E}{R + r/n}$

(d) P.d. across external resistance = p.d. across each cell = $V = iR$

(e) Current from each cell $i' = \frac{i}{n}$ (f) Power dissipated in the circuit $P = \left(\frac{E}{R + r/n}\right)^2 \cdot R$

(g) Condition for max power $R = r/n$ and $P_{max} = n \left(\frac{E^2}{4r}\right)$ (h) This type of combination is used when $nr \gg R$

(ii) **If non-identical cells are connected in parallel** : If cells are connected with right polarity as shown below then

(a) Equivalent emf $E_{eq} = \frac{E_1 r_2 + E_2 r_1}{r_1 + r_2}$

(b) Main current $i = \frac{E_{eq}}{r + R_{eq}}$

(c) Current from each cell $i_1 = \frac{E_1 - iR}{r_1}$ and $i_2 = \frac{E_2 - iR}{r_2}$

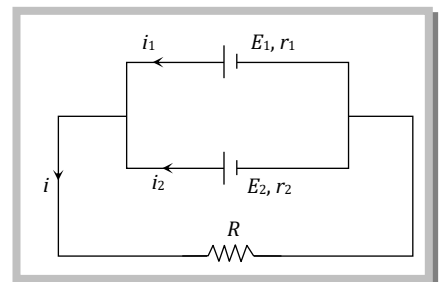
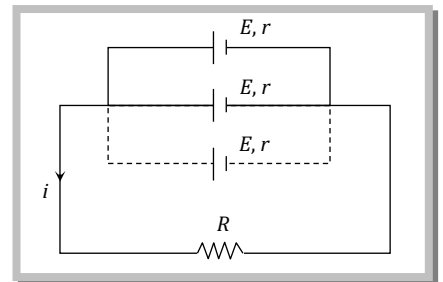

□ In this combination if cell's are connected with reversed polarity as shown in figure then :

Equivalent emf $E_{eq} = \frac{E_1 r_2 - E_2 r_1}{r_1 + r_2}$

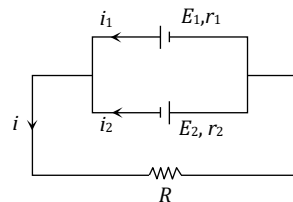

(3) **Mixed Grouping** : If n identical cell's are connected in a row and such m row's are connected in parallel as shown.

(i) Equivalent emf of the combination $E_{eq} = nE$

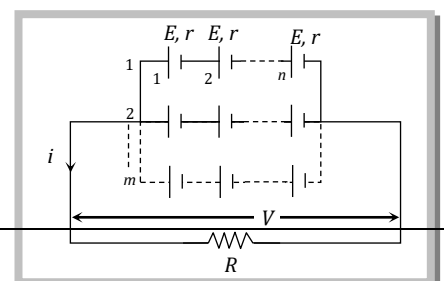

(ii) Equivalent internal resistance of the combination $r_{eq} = \frac{nr}{m}$

(iii) Main current flowing through the load $i = \frac{nE}{R + \frac{nr}{m}} = \frac{mnE}{mR + nr}$

(iv) Potential difference across load $V = iR$

(v) Potential difference across each cell $V' = \frac{V}{n}$

(vi) Current from each cell $i' = \frac{i}{n}$

(vii) Condition for maximum power $R = \frac{nr}{m}$ and $P_{max} = (mn) \frac{E^2}{4r}$

(viii) Total number of cell = mn

Concepts

☞ In series grouping of cell's their emf's are additive or subtractive while their internal resistances are always additive. If dissimilar plates of cells are connected together their emf's are added to each other while if their similar plates are connected together their emf's are subtractive.

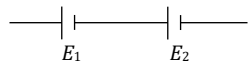

$$E_{eq} = E_1 + E_2 \text{ \& } r_{eq} = r_1 + r_2$$

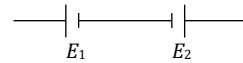

$$E_{eq} = E_1 - E_2 \text{ (} E_1 > E_2 \text{)} \text{ \& } r_{eq} = r_1 + r_2$$

☞ In series grouping of identical cells. If one cell is wrongly connected then it will cancel out the effect of two cells e.g. If in the combination of n identical cells (each having emf E and internal resistance r) if x cell are wrongly connected then equivalent emf $E_{eq} = (n - 2x)E$ and equivalent internal resistance $r_{eq} = nr$.

☞ In parallel grouping of two identical cell having no internal resistance

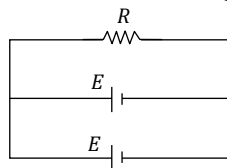

$$E_{eq} = E$$

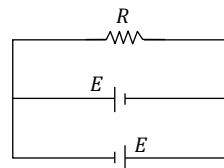

$$E_{eq} = 0$$

☞ When two cell's of different emf and no internal resistance are connected in parallel then equivalent emf is indeterminate, note that connecting a wire with a cell but with no resistance is equivalent to short circuiting. Therefore the total current that will be flowing will be infinity.

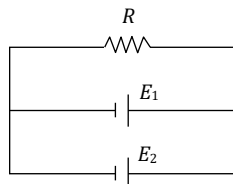

Example

Example: 56 A group of N cells whose emf varies directly with the internal resistance as per the equation $E_N = 1.5 r_N$ are connected as shown in the following figure. The current i in the circuit is

- (a) 0.51 amp
 (b) 5.1 amp
 (c) 0.15 amp
 (d) 1.5 amp

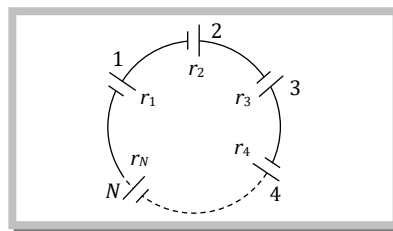

Solution : (d)
$$i = \frac{E_{eq}}{r_{eq}} = \frac{1.5r_1 + 1.5r_2 + 1.5r_3 + \dots}{r_1 + r_2 + r_3 + \dots} = 1.5 \text{ amp}$$

Example: 57 Two batteries A and B each of emf 2 volt are connected in series to external resistance $R = 1 \Omega$. Internal resistance of A is 1.9Ω and that of B is 0.9Ω , what is the potential difference between the terminals of battery A

- (a) 2 V
 (b) 3.8 V
 (c) 0
 (d) None of these

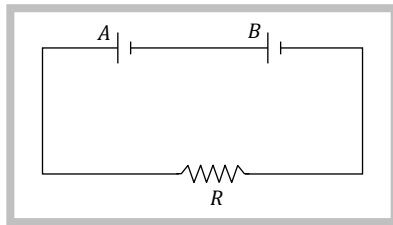

Solution : (c)
$$i = \frac{E_1 + E_2}{R + r_1 + r_2} = \frac{2 + 2}{1 + 1.9 + 0.9} = \frac{4}{3.8}$$
. Hence $V_A = E_A - ir_A = 2 - \frac{4}{3.8} \cdot 1.9 = 0$

Example: 58 In a mixed grouping of identical cells 5 rows are connected in parallel by each row contains 10 cell. This combination send a current i through an external resistance of 20Ω . If the emf and internal resistance of each cell is 1.5 volt and 1Ω respectively then the value of i is

- (a) 0.14 (b) 0.25 (c) 0.75 (d) 0.68

Solution : (d) No. of cells in a row $n = 10$; No. of such rows $m = 5$

$$i = \frac{nE}{\left(R + \frac{nr}{m}\right)} = \frac{10 \times 1.5}{\left(20 + \frac{10 \times 1}{5}\right)} = \frac{15}{22} = 0.68 \text{ amp}$$

Example: 59 To get maximum current in a resistance of 3Ω one can use n rows of m cells connected in parallel. If the total no. of cells is 24 and the internal resistance of a cell is 0.5Ω then

- (a) $m = 12, n = 2$ (b) $m = 8, n = 4$ (c) $m = 2, n = 12$ (d) $m = 6, n = 4$

Solution : (a) In this question $R = 3\Omega, mn = 24, r = 0.5\Omega$ and $R = \frac{mr}{n}$. On putting the values we get $n = 2$ and $m = 12$.

Example: 60 100 cells each of emf 5V and internal resistance 1Ω are to be arranged so as to produce maximum current in a 25Ω resistance. Each row contains equal number of cells. The number of rows should be

- (a) 2 (b) 4 (c) 5 (d) 100

Solution : (a) Total no. of cells, $= mn = 100$ (i)

Current will be maximum when $R = \frac{nr}{m}$; $25 = \frac{n \times 1}{m} \Rightarrow n = 25 m$ (ii)

From equation (i) and (ii) $n = 50$ and $m = 2$

Example: 61 In the adjoining circuit, the battery E_1 has an emf of 12 volt and zero internal resistance, while the battery E has an emf of 2 volt. If the galvanometer reads zero, then the value of resistance X ohm is

- (a) 10
- (b) 100
- (c) 500
- (d) 200

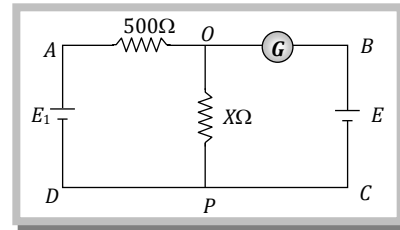

Solution: (b) For zero deflection in galvanometer the potential difference across X should be $E = 2V$

$$\text{In this condition } \frac{12X}{500 + X} = 2$$

$$\therefore X = 100 \Omega$$

Example: 62 In the circuit shown here $E_1 = E_2 = E_3 = 2V$ and $R_1 = R_2 = 4 \Omega$. The current flowing between point A and B through battery E_2 is

- (a) Zero
- (b) 2 A from A to B
- (c) 2 A from B to A
- (d) None of these

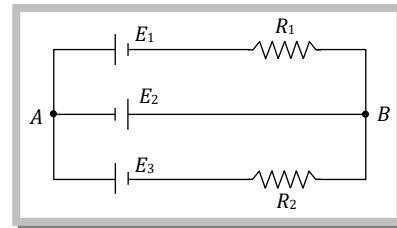

Solution: (b) The equivalent circuit can be drawn as since E_1 & E_3 are parallelly connected

$$\text{So current } i = \frac{2 + 2}{2} = 2 \text{ Amp from } A \text{ to } B.$$

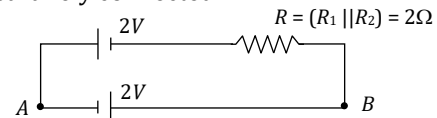

Example: 63 The magnitude and direction of the current in the circuit shown will be

- (a) $\frac{7}{3}$ A from a to b through e
- (b) $\frac{7}{3}$ A from b and a through e
- (c) 1.0 A from b to a through e
- (d) 1.0 A from a to b through e

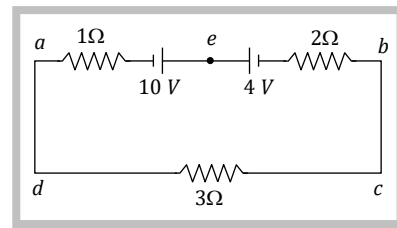

Solution: (d) Current $i = \frac{10 - 4}{3 + 2 + 1} = 1A$ from a to b via e

Example: 64 Figure represents a part of the closed circuit. The potential difference between points A and B ($V_A - V_B$) is

- (a) +9 V
- (b) -9 V
- (c) +3 V
- (d) +6 V

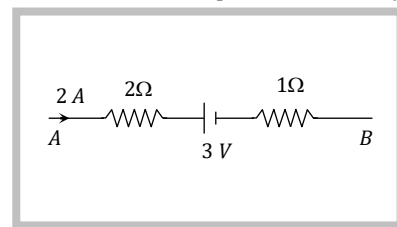

Solution: (a) The given part of a closed circuit can be redrawn as follows. It should be remembered that product of current and resistance can be treated as an imaginary cell having emf = iR .

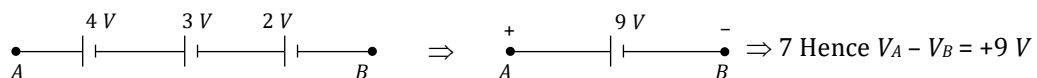

Example: 65 In the circuit shown below the cells E_1 and E_2 have emf's 4 V and 8 V and internal resistance 0.5 ohm and 1 ohm respectively. Then the potential difference across cell E_1 and E_2 will be

- (a) 3.75 V, 7.5 V
- (b) 4.25 V, 7.5 V
- (c) 3.75 V, 3.5 V
- (d) 4.25 V, 4.25 V

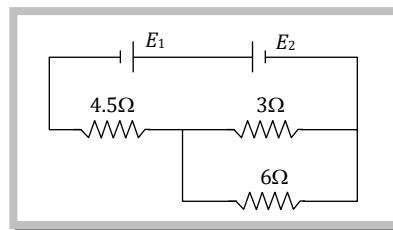

Solution : (b) In the given circuit diagram external resistance $R = \frac{3 \times 6}{3 + 6} + 4.5 = 6.5 \Omega$. Hence main current through the

$$\text{circuit } i = \frac{E_2 - E_1}{R + r_{eq}} = \frac{8 - 4}{6.5 + 0.5 + 0.5} = \frac{1}{2} \text{ amp.}$$

$$\text{Cell 1 is charging so from it's emf equation } E_1 = V_1 - ir_1 \Rightarrow 4 = V_1 - \frac{1}{2} \times 0.5 \Rightarrow V_1 = 4.25 \text{ volt}$$

$$\text{Cell 2 is discharging so from it's emf equation } E_2 = V_2 + ir_2 \Rightarrow 8 = V_2 + \frac{1}{2} \times 1 \Rightarrow V_2 = 7.5 \text{ volt}$$

Example: 66 A wire of length L and 3 identical cells of negligible internal resistances are connected in series. Due to this current, the temperature of the wire is raised by ΔT in time t . A number N of similar cells is now connected in series with a wire of the same material and cross-section but of length $2L$. The temperature of wire is raised by same amount ΔT in the same time t . The value of N is

- (a) 4
- (b) 6
- (c) 8
- (d) 9

Solution : (b) Heat = $mS\Delta T = i^2Rt$

Case I : Length (L) \Rightarrow Resistance = R and mass = m

Case II : Length ($2L$) \Rightarrow Resistance = $2R$ and mass = $2m$

$$\text{So } \frac{m_1 S_1 \Delta T_1}{m_2 S_2 \Delta T_2} = \frac{i_1^2 R_1 t_1}{i_2^2 r_2 t_2} \Rightarrow \frac{mS \Delta T}{2mS \Delta T} = \frac{i_1^2 Rt}{i_2^2 2Rt} \Rightarrow i_1 = i_2 \Rightarrow \frac{(3E)^2}{12} = \frac{(NE)^2}{2R} \Rightarrow N = 6$$

Example: 8

n identical cells, each of emf E and internal resistance r , are joined in series to form a closed circuit. The potential difference across any one cell is

- (a) Zero
- (b) E
- (c) $\frac{E}{n}$
- (d) $\left(\frac{n-1}{n}\right)E$

Solution: (a) Current in the circuit $i = \frac{nE}{nr} = \frac{E}{r}$

The equivalent circuit of one cell is shown in the figure. Potential difference across the cell

$$= V_A - V_B = -E + ir = -E + \frac{E}{r} \cdot r = 0$$

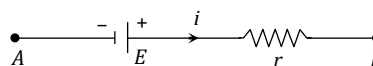

Kirchoff's Laws

(1) **Kirchoff's first law :** This law is also known as junction rule or current law (KCL). According to it the algebraic sum of currents meeting at a junction is zero *i.e.* $\sum i = 0$.

In a circuit, at any junction the sum of the currents entering the junction must equal the sum of the currents leaving the junction. $i_1 + i_3 = i_2 + i_4$

Here it is worthy to note that :

(i) If a current comes out to be negative, actual direction of current at the junction is opposite to that assumed, $i + i_1 + i_2 = 0$ can be satisfied only if at least one current is negative, *i.e.* leaving the junction.

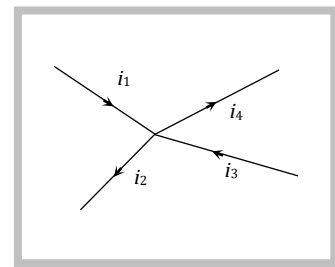

(ii) This law is simply a statement of "conservation of charge" as if current reaching a junction is not equal to the current leaving the junction, charge will not be conserved.

- This law is also applicable to a capacitor through the concept of displacement current treating the resistance of capacitor to be zero during charging or discharging and infinite in steady state as shown in figure.

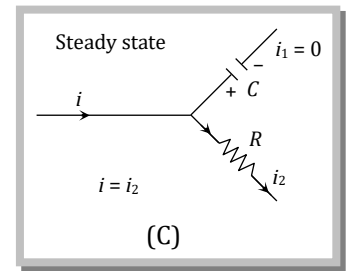
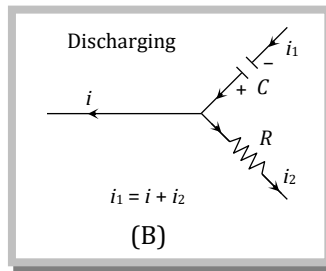
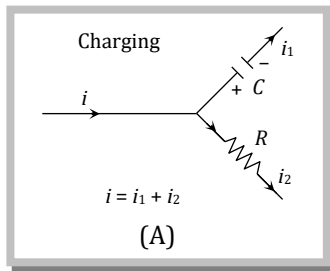

(2) **Kirchoff's second law** : This law is also known as loop rule or voltage law (KVL) and according to it “the algebraic sum of the changes in potential in complete traversal of a mesh (closed loop) is zero”, i.e. $\sum V = 0$

e.g. In the following closed loop.

$$-i_1R_1 + i_2R_2 - E_1 - i_3R_3 + E_2 + E_3 - i_4R_4 = 0$$

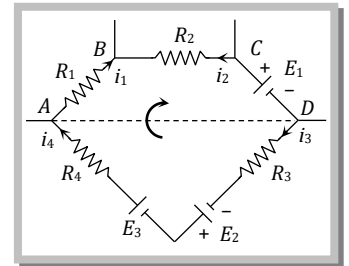

Here it is worthy to note that :

(i) This law represents “*conservation of energy*” as if the sum of potential changes around a closed loop is not zero, unlimited energy could be gained by repeatedly carrying a charge around a loop.

(ii) If there are n meshes in a circuit, the number of independent equations in accordance with loop rule will be $(n - 1)$.

(3) **Sign convention for the application of Kirchoff's law** : For the application of Kirchoff's laws following sign convention are to be considered

(i) The change in potential in traversing a resistance in the direction of current is $-iR$ while in the opposite direction $+iR$

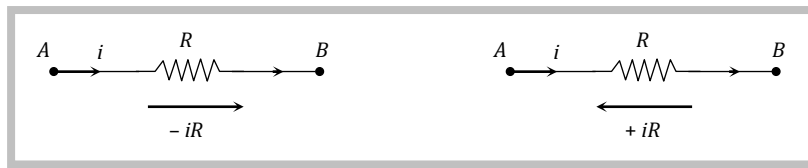

(ii) The change in potential in traversing an emf source from negative to positive terminal is $+E$ while in the opposite direction $-E$ irrespective of the direction of current in the circuit.

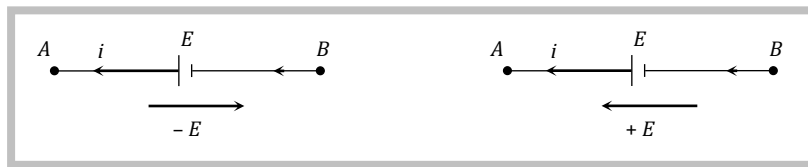

(iii) The change in potential in traversing a capacitor from the negative terminal to the positive terminal is $+\frac{q}{C}$ while in opposite direction $-\frac{q}{C}$.



(iv) The change in voltage in traversing an inductor in the direction of current is $-L \frac{di}{dt}$ while in opposite direction it is $+L \frac{di}{dt}$.

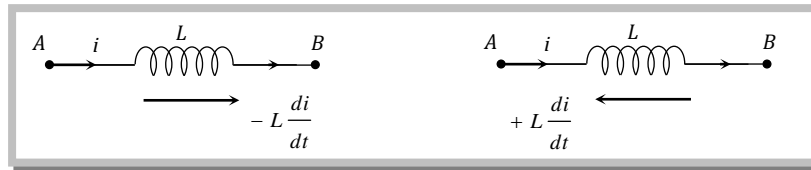

(4) Guidelines to apply Kirchoff's law

(i) Starting from the positive terminal of the battery having highest emf, distribute current at various junctions in the circuit in accordance with 'junction rule'. It is not always easy to correctly guess the direction of current, no problem if one assumes the wrong direction.

(ii) After assuming current in each branch, we pick a point and begin to walk (mentally) around a closed loop. As we traverse each resistor, capacitor, inductor or battery we must write down, the voltage change for that element according to the above sign convention.

(iii) By applying KVL we get one equation but in order to solve the circuit we require as many equations as there are unknowns. So we select the required number of loops and apply Kirchoff's voltage law across each such loop.

(iv) After solving the set of simultaneous equations, we obtain the numerical values of the assumed currents. If any of these values come out to be negative, it indicates that particular current is in the opposite direction from the assumed one.

- ❑ The number of loops must be selected so that every element of the circuit must be included in at least one of the loops.
- ❑ While traversing through a capacitor or battery we do not consider the direction of current.
- ❑ While considering the voltage drop or gain across an inductor we always assume current to be in increasing function.

(5) **Determination of equivalent resistance by Kirchoff's method** : This method is useful when we are not able to identify any two resistances in series or in parallel. It is based on the two Kirchoff's laws. The method may be described in the following guideline.

(i) Assume an imaginary battery of emf E connected between the two terminals across which we have to calculate the equivalent resistance.

(ii) Assume some value of current, say i , coming out of the battery and distribute it among each branch by applying Kirchoff's current law.

(iii) Apply Kirchoff's voltage law to formulate as many equations as there are unknowns. It should be noted that at least one of the equations must include the assumed battery.

(iv) Solve the equations to determine $\frac{E}{i}$ ratio which is the equivalent resistance of the network.

e.g. Suppose in the following network of 12 identical resistances, equivalent resistance between point A and C is to be calculated.

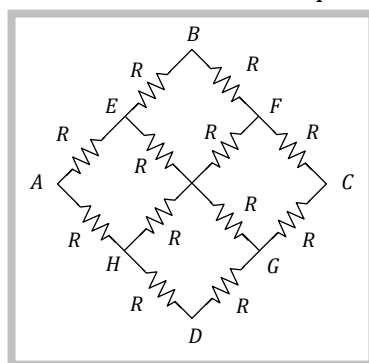

According to the above guidelines we can solve this problem as follows

Step (1)

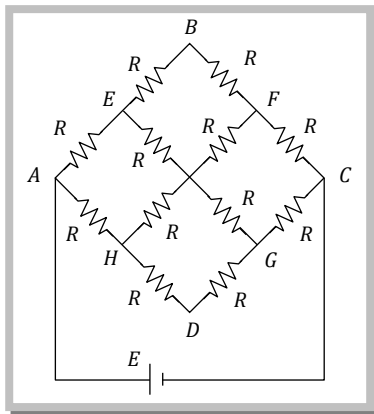

An imaginary battery of emf E is assumed across the terminals A and C

Step (2)

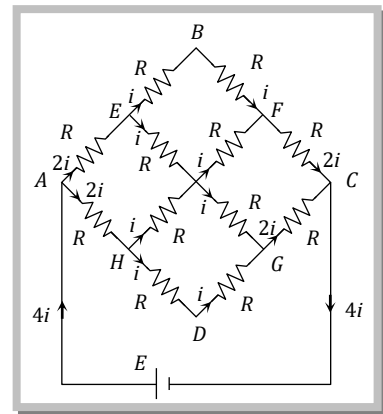

The current in each branch is distributed by assuming $4i$ current coming out of the battery.

Step (3) Applying KVL along the loop including the nodes A, B, C and the battery E . Voltage equation is $-2iR - iR - iR - 2iR + E = 0$

Step (4) After solving the above equation, we get $6iR = E \Rightarrow$ equivalent resistance between A and C is $R = \frac{E}{4i} = \frac{6iR}{4i} = \frac{3}{2}R$

Concepts

☞ Using Kirchoff's law while dividing the current having a junction through different arms of a network, it will be same through different arms of same resistance if the end points of these arms are equilocated w.r.t. exit point for current in network and will be different through different arms if the end point of these arms are not equilocated w.r.t. exit point for current of the network. e.g. In the following figure the current going in arms AB, AD and AL will be same because the location of end points B, D and L of these arms are symmetrically located w.r.t. exit point N of the network.

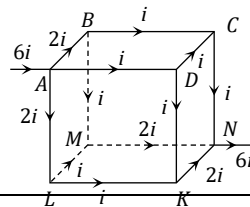

Example

Example: 67

In the following circuit $E_1 = 4V$, $R_1 = 2\Omega$
 $E_2 = 6V$, $R_2 = 2\Omega$ and $R_3 = 4\Omega$. The current i_1 is

- (a) 1.6 A
- (b) 1.8 A
- (c) 2.25 A
- (d) 1 A

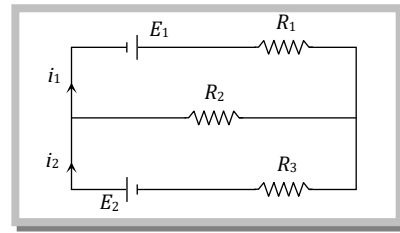

Solution : (b)

For loop (1) $-2i_1 - 2(i_1 - i_2) + 4 = 0 \Rightarrow 2i_1 - i_2 = 2$ (i)

For loop (2) $-4i_2 + 2(i_1 - i_2) + 6 = 0 \Rightarrow 3i_2 - i_1 = 3$ (ii)

After solving equation (i) and (ii) we get $i_1 = 1.8A$ and $i_2 = 1.6A$

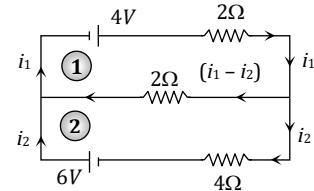

Example: 68

Determine the current in the following circuit

- (a) 1 A
- (b) 2.5 A
- (c) 0.4 A
- (d) 3 A

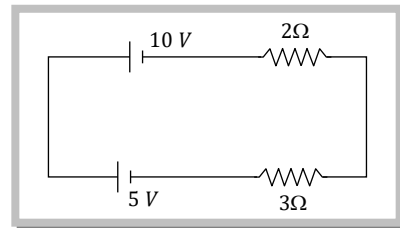

Solution : (a)

Applying KVL in the given circuit we get $-2i + 10 - 5 - 3i = 0 \Rightarrow i = 1A$

Second method : Similar plates of the two batteries are connected together, so the net emf = $10 - 5 = 5V$
 Total resistance in the circuit = $2 + 3 = 5\Omega$

$$\therefore i = \frac{\Sigma V}{\Sigma R} = \frac{5}{5} = 1A$$

Example: 69

In the circuit shown in figure, find the current through the branch BD

- (a) 5 A
- (b) 0 A
- (c) 3 A
- (d) 4 A

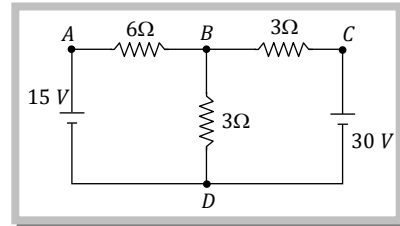

Solution : (a)

The current in the circuit are assumed as shown in the fig. Applying KVL along the loop ABDA, we get

$$-6i_1 - 3i_2 + 15 = 0 \quad \text{or} \quad 2i_1 + i_2 = 5 \quad \text{..... (i)}$$

Applying KVL along the loop BCDB, we get

$$-3(i_1 - i_2) - 30 + 3i_2 = 0 \quad \text{or} \quad -i_1 + 2i_2 = 10 \quad \text{..... (ii)}$$

Solving equation (i) and (ii) for i_2 , we get $i_2 = 5A$

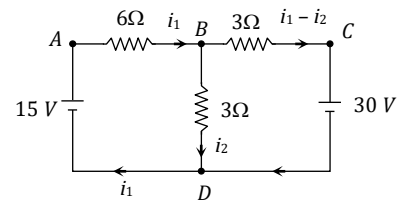

Example: 70

The figure shows a network of currents. The magnitude of current is shown here. The current i will be

- (a) 3 A
- (b) 13 A
- (c) 23 A
- (d) -3 A

Solution : (c)

$$i = 15 + 3 + 5 = 23A$$

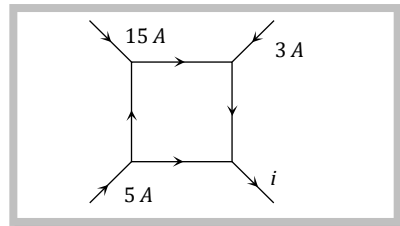

Example: 71

Consider the circuit shown in the figure. The current i_3 is equal to

- (a) 5 amp

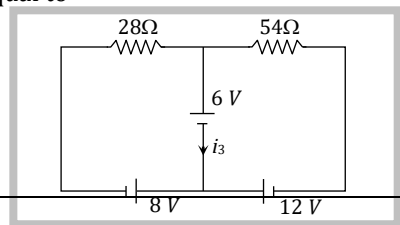

- (b) 3 amp
- (c) - 3 amp
- (d) - 5/6 amp

Solution : (d) Suppose current through different paths of the circuit is as follows.

After applying KVL for loop (1) and loop (2)

We get $28 i_1 = -6 - 8 \Rightarrow i_1 = -\frac{1}{2} A$

and $54 i_2 = -6 - 12 \Rightarrow i_2 = -\frac{1}{3} A$

Hence $i_3 = i_1 + i_2 = -\frac{5}{6} A$

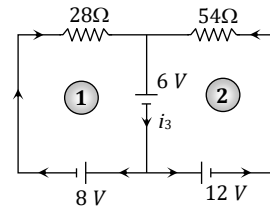

Example: 72 A part of a circuit in steady state along with the current flowing in the branches, with value of each resistance is shown in figure. What will be the energy stored in the capacitor C_0

- (a) $6 \times 10^{-4} J$
- (b) $8 \times 10^{-4} J$
- (c) $16 \times 10^{-4} J$
- (d) Zero

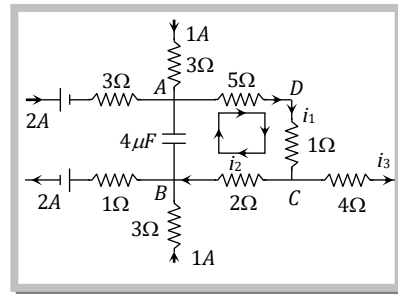

Solution : (b) Applying Kirchoff's first law at junctions A and B respectively we have $2 + 1 - i_1 = 0$ i.e., $i_1 = 3A$ and $i_2 + 1 - 2 - 0 = 0$ i.e., $i_2 = 1A$

Now applying Kirchoff's second law to the mesh ADCBA treating capacitor as a seat of emf V in open circuit $- 3 \times 5 - 3 \times 1 - 1 \times 2 + V = 0$ i.e. $V (= V_A - V_B) = 20 V$

So, energy stored in the capacitor $U = \frac{1}{2} CV^2 = \frac{1}{2} (4 \times 10^{-6}) \times (20)^2 = 8 \times 10^{-4} J$

Example: 73 In the following circuit the potential difference between P and Q is

- (a) 15 V
- (b) 10 V
- (c) 5 V
- (d) 2.5 V

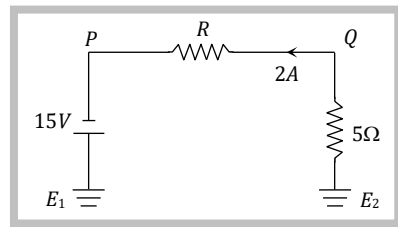

Solution : (c) By using KVL $-5 \times 2 - V_{PQ} + 15 = 0 \Rightarrow V_{PQ} = 5V$

Different Measuring Instruments.

(1) **Galvanometer** : It is an instrument used to detect small current passing through it by showing deflection. Galvanometers are of different types *e.g.* moving coil galvanometer, moving magnet galvanometer, hot wire galvanometer. In dc circuit usually moving coil galvanometer are used.

(i) **It's symbol** :  ; where G is the total internal resistance of the galvanometer.

(ii) **Principle** : In case of moving coil galvanometer deflection is directly proportional to the current that passes through it *i.e.* $i \propto \theta$.

(iii) **Full scale deflection current** : The current required for full scale deflection in a galvanometer is called full scale deflection current and is represented by i_g .

(iv) **Shunt** : The small resistance connected in parallel to galvanometer coil, in order to control current flowing through the galvanometer is known as shunt.

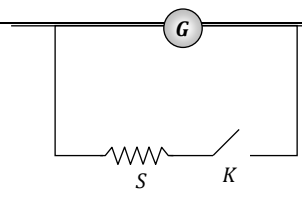
Merits of shunt	Demerits of shunt	
(a) To protect the galvanometer coil from burning (b) It can be used to convert any galvanometer into ammeter of desired range.	Shunt resistance decreases the sensitivity of galvanometer.	

(2) **Ammeter** : It is a device used to measure current and is always connected in series with the 'element' through which current is to be measured.

(i) The reading of an ammeter is always lesser than actual current in the circuit.

(ii) Smaller the resistance of an ammeter more accurate will be its reading. An ammeter is said to be ideal if its resistance r is zero.

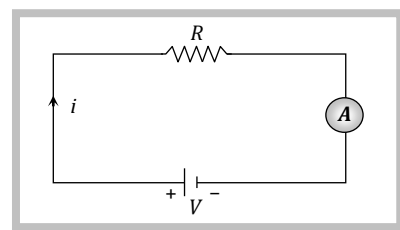

(iii) **Conversion of galvanometer into ammeter** : A galvanometer may be converted into an ammeter by connecting a low resistance (called shunt S) in parallel to the galvanometer G as shown in figure.

(a) Equivalent resistance of the combination = $\frac{GS}{G + S}$

(b) G and S are parallel to each other hence both will have equal potential difference *i.e.* $i_g G = (i - i_g)S$; which gives

$$\text{Required shunt } S = \frac{i_g}{i - i_g} G$$

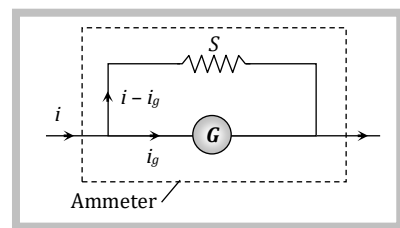

(c) To pass n th part of main current (*i.e.* $i_g = \frac{i}{n}$) through the galvanometer, required shunt $S = \frac{G}{(n - 1)}$.

(3) **Voltmeter** : It is a device used to measure potential difference and is always put in parallel with the 'circuit element' across which potential difference is to be measured.

(i) The reading of a voltmeter is always lesser than true value.

(ii) Greater the resistance of voltmeter, more accurate will be its reading. A voltmeter is said to be ideal if its resistance is infinite, *i.e.*, it draws no current from the circuit element for its operation.

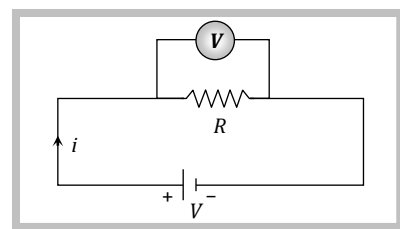

(iii) **Conversion of galvanometer into voltmeter** : A galvanometer may be converted into a voltmeter by connecting a large resistance R in series with the galvanometer as shown in the figure.

(a) Equivalent resistance of the combination = $G + R$

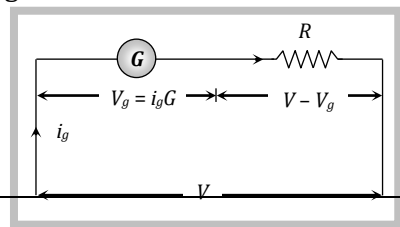

(b) According to ohm's law $V = i_g (G + R)$; which gives

$$\text{Required series resistance } R = \frac{V}{i_g} - G = \left(\frac{V}{V_g} - 1 \right) G$$

(c) If n^{th} part of applied voltage appeared across galvanometer (i.e. $V_g = \frac{V}{n}$) then required series resistance $R = (n - 1) G$.

(4) **Wheatstone bridge** : Wheatstone bridge is an arrangement of four resistance which can be used to measure one of them in terms of rest. Here arms AB and BC are called ratio arm and arms AC and BD are called conjugate arms

(i) **Balanced bridge** : The bridge is said to be balanced when deflection in galvanometer is zero i.e. no current flows through the galvanometer or in other words $V_B = V_D$. In the balanced condition $\frac{P}{Q} = \frac{R}{S}$, on mutually changing the position of cell and galvanometer this condition will not change.

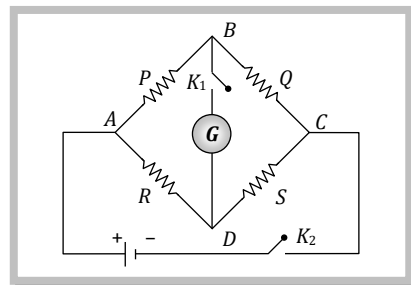

(ii) **Unbalanced bridge** : If the bridge is not balanced current will flow from D to B if $V_D > V_B$ i.e. $(V_A - V_D) < (V_A - V_B)$ which gives $PS > RQ$.

(iii) **Applications of wheatstone bridge** : Meter bridge, post office box and Carey Foster bridge are instruments based on the principle of wheatstone bridge and are used to measure unknown resistance.

(5) **Meter bridge** : In case of meter bridge, the resistance wire AC is 100 cm long. Varying the position of tapping point B , bridge is balanced. If in balanced position of bridge $AB = l$, $BC = (100 - l)$ so that $\frac{Q}{P} = \frac{(100 - l)}{l}$. Also

$$\frac{P}{Q} = \frac{R}{S} \Rightarrow S = \frac{(100 - l)}{l} R$$

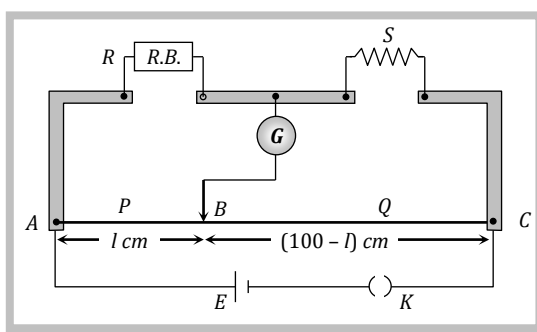

Concepts

- ☞ Wheatstone bridge is most sensitive if all the arms of bridge have equal resistances i.e. $P = Q = R = S$
- ☞ If the temperature of the conductor placed in the right gap of metre bridge is increased, then the balancing length decreases and the jockey moves towards left.
- ☞ In Wheatstone bridge to avoid inductive effects the battery key should be pressed first and the galvanometer key afterwards.
- ☞ The measurement of resistance by Wheatstone bridge is not affected by the internal resistance of the cell.

Example

Example: 74 The scale of a galvanometer of resistance 100Ω contains 25 divisions. It gives a deflection of one division on passing a current of $4 \times 10^{-4} A$. The resistance in ohms to be added to it, so that it may become a voltmeter of range 2.5 volt is

- (a) 100 (b) 150 (c) 250 (d) 300

Solution : (b) Current sensitivity of galvanometer = $4 \times 10^{-4} \text{ Amp/div}$.

So full scale deflection current (i_g) = Current sensitivity \times Total number of division = $4 \times 10^{-4} \times 25 = 10^{-2} A$

To convert galvanometer in to voltmeter, resistance to be put in series is $R = \frac{V}{i_g} - G = \frac{2.5}{10^{-2}} - 100 = 150 \Omega$

Example: 75 A galvanometer, having a resistance of 50Ω gives a full scale deflection for a current of $0.05 A$. the length in meter of a resistance wire of area of cross-section $2.97 \times 10^{-2} \text{ cm}^2$ that can be used to convert the galvanometer into an ammeter which can read a maximum of $5A$ current is : (Specific resistance of the wire = $5 \times 10^{-7} \Omega m$)

- (a) 9 (b) 6 (c) 3 (d) 1.5

Solution : (c) Given $G = 50 \Omega$, $i_g = 0.05 \text{ Amp.}$, $i = 5A$, $A = 2.97 \times 10^{-2} \text{ cm}^2$ and $\rho = 5 \times 10^{-7} \Omega\text{-m}$

By using $\frac{i}{i_g} = 1 + \frac{G}{S} \Rightarrow S = \frac{G \cdot i_g}{(i - i_g)} \Rightarrow \frac{\rho l}{A} = \frac{G i_g}{(i - i_g)} \Rightarrow l = \frac{G i_g A}{(i - i_g) \rho}$ on putting values $l = 3 \text{ m}$.

Example: 76 100 mA current gives a full scale deflection in a galvanometer of resistance 2Ω . The resistance connected with the galvanometer to convert it into a voltmeter of 5 V range is

- (a) 98Ω (b) 52Ω (c) 80Ω (d) 48Ω

Solution : (d) $R = \frac{V}{I_g} - G = \frac{5}{100 \times 10^{-3}} - 2 = 50 - 2 = 48 \Omega$.

Example: 77 A milliammeter of range 10 mA has a coil of resistance 1Ω . To use it as voltmeter of range 10 volt , the resistance that must be connected in series with it will be

- (a) 999Ω (b) 99Ω (c) 1000Ω (d) None of these

Solution : (a) By using $R = \frac{V}{i_g} - G \Rightarrow R = \frac{10}{10 \times 10^{-3}} - 1 = 999 \Omega$

Example: 78 In the following figure ammeter and voltmeter reads 2 amp and 120 volt respectively. Resistance of voltmeter is

- (a) 100Ω
(b) 200Ω
(c) 300Ω
(d) 400Ω

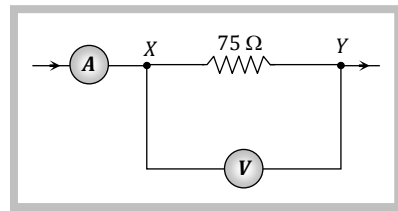

Solution : (c) Let resistance of voltmeter be R_V . Equivalent resistance between X and Y is $R_{XY} = \frac{75 R_V}{75 + R_V}$

Reading of voltmeter = potential difference across X and Y = $120 = i \times R_{XY} = 2 \times \frac{75 R_V}{75 + R_V} \Rightarrow R_V = 300 \Omega$

Example: 79 In the circuit shown in figure, the voltmeter reading would be

- (a) Zero
(b) 0.5 volt
(c) 1 volt
(d) 2 volt

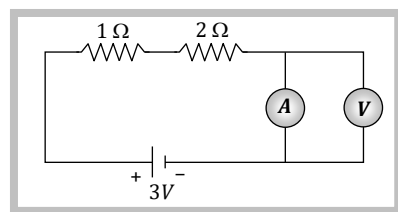

Solution : (a) Ammeter has no resistance so there will be no potential difference across it, hence reading of voltmeter is zero.

Example: 80 Voltmeters V_1 and V_2 are connected in series across a d.c. line. V_1 reads 80 V and has a per volt resistance of 200 Ω , V_2 has a total resistance of 32 k Ω . The line voltage is

- (a) 120 V (b) 160 V (c) 220 V (d) 240 V

Solution : (d) Resistance of voltmeter V_1 is $R_1 = 200 \times 80 = 16000 \Omega$ and resistance of voltmeter V_2 is $R_2 = 32000 \Omega$

By using relation $V' = \left(\frac{R'}{R_{eq}} \right) V$; where V' = potential difference across any resistance R' in a series grouping.

So for voltmeter V_1 potential difference across it is

$$80 = \left(\frac{R_1}{R_1 + R_2} \right) V \Rightarrow V = 240 V$$

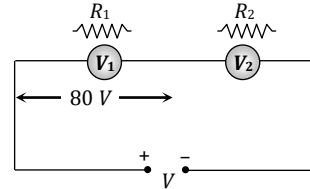

Example: 81 The resistance of 1 A ammeter is 0.018 Ω . To convert it into 10 A ammeter, the shunt resistance required will be

- (a) 0.18 Ω (b) 0.0018 Ω (c) 0.002 Ω (d) 0.12 Ω

Solution : (c) By using $\frac{i}{i_g} = 1 + \frac{4}{S} \Rightarrow \frac{10}{1} = 1 + \frac{0.018}{S} \Rightarrow S = 0.002 \Omega$

Example: 82 In meter bridge the balancing length from left and when standard resistance of 1 Ω is in right gap is found to be 20 cm. The value of unknown resistance is

- (a) 0.25 Ω (b) 0.4 Ω (c) 0.5 Ω (d) 4 Ω

Solution: (a) The condition of wheatstone bridge gives $\frac{X}{R} = \frac{20r}{80r}$, r - resistance of wire per cm, X - unknown resistance

$$\therefore X = \frac{20}{80} \times R = \frac{1}{4} \times 1 = 0.25 \Omega$$

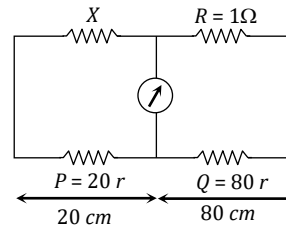

Example: 83 A galvanometer having a resistance of 8 Ω is shunted by a wire of resistance 2 Ω . If the total current is 1 amp, the part of it passing through the shunt will be

- (a) 0.25 amp (b) 0.8 amp (c) 0.2 amp (d) 0.5 amp

Solution: (b) Fraction of current passing through the galvanometer

$$\frac{i_g}{i} = \frac{S}{S + G} \text{ or } \frac{i_g}{i} = \frac{2}{2 + 8} = 0.2$$

So fraction of current passing through the shunt

$$\frac{i_s}{i} = 1 - \frac{i_g}{i} = 1 - 0.2 = 0.8 \text{ amp}$$

Example: 84 A moving coil galvanometer is converted into an ammeter reading upto 0.03 A by connecting a shunt of resistance 4r across it and into an ammeter reading upto 0.06 A when a shunt of resistance r connected across it. What is the maximum current which can be through this galvanometer if no shunt is used

- (a) 0.01 A (b) 0.02 A (c) 0.03 A (d) 0.04 A

Solution: (b) For ammeter, $S = \frac{i_g}{(i - i_g)} G \Rightarrow i_g G = (i - i_g) S$

So $i_g G = (0.03 - i_g) 4r$ (i) and $i_g G = (0.06 - i_g) r$ (ii)

Dividing equation (i) by (ii) $1 = \frac{(0.03 - i_g)4}{0.06 - i_g} \Rightarrow 0.06 - i_g = 0.12 - 4i_g$
 $\Rightarrow 3i_g = 0.06 \Rightarrow i_g = 0.02 \text{ A}$

Example: 10

The ammeter A reads 2 A and the voltmeter V reads 20 V . The value of resistance R is

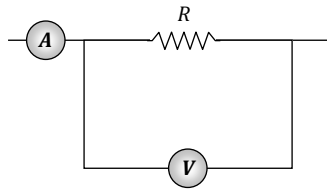

- (a) Exactly 10 ohm
- (b) Less than 10 ohm
- (c) More than 10 ohm
- (d) We cannot definitely say

Solution: (c) If current goes through the resistance R is i then $iR = 20 \text{ volt} \Rightarrow R = \frac{20}{i}$. Since $i < 2\text{A}$ so $R > 10\Omega$.

Potentiometer

Potentiometer is a device mainly used to measure emf of a given cell and to compare emf's of cells. It is also used to measure internal resistance of a given cell.

(1) **Superiority of potentiometer over voltmeter** : An ordinary voltmeter cannot measure the emf accurately because it does draw some current to show the deflection. As per definition of emf, it is the potential difference when a cell is in open circuit or no current through the cell. Therefore voltmeter can only measure terminal voltage of a give n cell.

Potentiometer is based on no deflection method. When the potentiometer gives zero deflection, it does not draw any current from the cell or the circuit *i.e.* potentiometer is effectively an ideal instrument of infinite resistance for measuring the potential difference.

(2) **Circuit diagram** : Potentiometer consists of a long resistive wire AB of length L (about 6m to 10 m long) made up of mangnine or constantan. A battery of known voltage e and internal resistance r called supplier battery or driver cell. Connection of these two forms primary circuit.

One terminal of another cell (whose emf E is to be measured) is connected at one end of the main circuit and the other terminal at any point on the resistive wire through a galvanometer G . This forms the secondary circuit. Other details are as follows

J = Jockey

K = Key

R = Resistance of potentiometer wire,

ρ = Specific resistance of potentiometer wire.

R_h = Variable resistance which controls the current through the wire AB

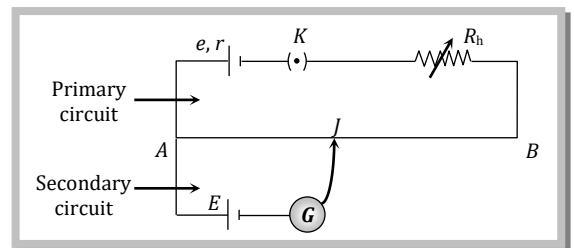

(3) **Points to be remember**

(i) The specific resistance (ρ) of potentiometer wire must be high but its temperature coefficient of resistance (α) must be low.

(ii) All higher potential points (terminals) of primary and secondary circuits must be connected together at point A and all lower potential points must be connected to point B or jockey.

(iii) The value of known potential difference must be greater than the value of unknown potential difference to be measured.

(iv) The potential gradient must remain constant. For this the current in the primary circuit must remain constant and the jockey must not be slid in contact with the wire.

(v) The diameter of potentiometer wire must be uniform everywhere.

(4) **Potential gradient (x)** : Potential difference (or fall in potential) per unit length of wire is called potential gradient *i.e.* $x = \frac{V \text{ volt}}{L \text{ m}}$ where $V = iR = \left(\frac{e}{R + R_h + r} \right) R$. So $x = \frac{V}{L} = \frac{iR}{L} = \frac{i\rho}{A} = \frac{e}{(R + R_h + r)} \cdot \frac{R}{L}$

(i) Potential gradient directly depends upon

- (a) The resistance per unit length (R/L) of potentiometer wire.
- (b) The radius of potentiometer wire (*i.e.* Area of cross-section)
- (c) The specific resistance of the material of potentiometer wire (*i.e.* ρ)
- (d) The current flowing through potentiometer wire (i)

(ii) x indirectly depends upon

- (a) The emf of battery in the primary circuit (*i.e.* e)
- (b) The resistance of rheostat in the primary circuit (*i.e.* R_h)

□ When potential difference V is constant then $\frac{x_1}{x_2} = \frac{L_2}{L_1}$

□ Two different wire are connected in series to form a potentiometer wire then $\frac{x_1}{x_2} = \frac{R_1}{R_2} \cdot \frac{L_2}{L_1}$

□ If the length of a potentiometer wire and potential difference across it's ends are kept constant and if it's diameter is changed from $d_1 \rightarrow d_2$ then potential gradient remains unchanged.

□ The value of x does not change with any change effected in the secondary circuit.

(5) **Working** : Suppose jockey is made to touch a point J on wire then potential difference between A and J will be $V = xl$

At this length (l) two potential difference are obtained

- (i) V due to battery e and
- (ii) E due to unknown cell

If $V > E$ then current will flow in galvanometer circuit in one direction 

If $V < E$ then current will flow in galvanometer circuit in opposite direction 

If $V = E$ then no current will flow in galvanometer circuit this condition to known as null deflection position, length l is known as balancing length.

In balanced condition $E = xl$ or $E = xl = \frac{V}{L} l = \frac{iR}{L} l = \left(\frac{e}{R + R_h + r} \right) \cdot \frac{R}{L} \times l$

□ If V is constant then $L \propto l \Rightarrow \frac{L_1}{L_2} = \frac{l_1}{l_2}$

(6) **Standardization of potentiometer** : The process of determining potential gradient experimentally is known as standardization of potentiometer.

Let the balancing length for the standard emf E_0 is l_0 then by the principle of potentiometer $E_0 = xl_0 \Rightarrow x = \frac{E_0}{l_0}$

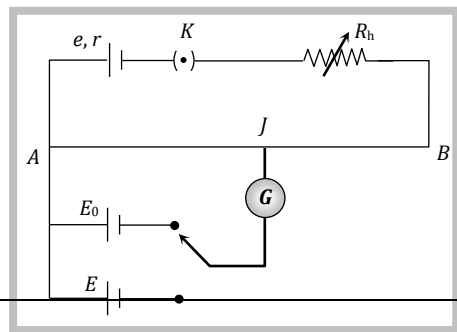
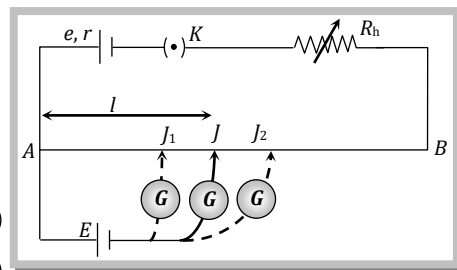

(7) **Sensitivity of potentiometer** : A potentiometer is said to be more sensitive, if it measures a small potential difference more accurately.

(i) The sensitivity of potentiometer is assessed by its potential gradient. The sensitivity is inversely proportional to the potential gradient.

(ii) In order to increase the sensitivity of potentiometer

(a) The resistance in primary circuit will have to be decreased.

(b) The length of potentiometer wire will have to be increased so that the length may be measured more accuracy.

(8) **Difference between voltmeter and potentiometer**

	Voltmeter	Potentiometer
(i)	It's resistance is high but finite	Its resistance is high but infinite
(ii)	It draws some current from source of emf	It does not draw any current from the source of known emf
(iii)	The potential difference measured by it is lesser than the actual potential difference	The potential difference measured by it is equal to actual potential difference
(iv)	Its sensitivity is low	Its sensitivity is high
(v)	It is a versatile instrument	It measures only emf or potential difference
(vi)	It is based on deflection method	It is based on zero deflection method

Application of Potentiometer.

(1) **To determine the internal resistance of a primary cell**

(i) Initially in secondary circuit key K' remains open and balancing length (l_1) is obtained. Since cell E is in open circuit so it's emf balances on length l_1 i.e. $E = xl_1$ (i)

(ii) Now key K' is closed so cell E comes in closed circuit. If the process is repeated again then potential difference V balances on length l_2 i.e. $V = xl_2$ (ii)

(iii) By using formula internal resistance $r = \left(\frac{E}{V} - 1 \right) \cdot R'$

$$r = \left(\frac{l_1 - l_2}{l_2} \right) \cdot R'$$

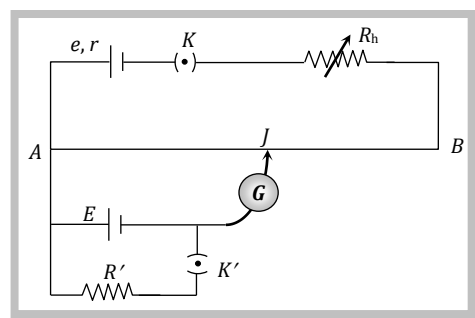

(2) **Comparison of emf's of two cell** : Let l_1 and l_2 be the balancing lengths with the cells E_1 and E_2

respectively then $E_1 = xl_1$ and $E_2 = xl_2 \Rightarrow \frac{E_1}{E_2} = \frac{l_1}{l_2}$

□ Let $E_1 > E_2$ and both are connected in series. If balancing length is l_1 when cell assist each other and it is l_2 when they oppose each other as shown then :

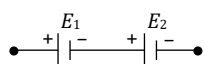

$$(E_1 + E_2) = xl_1$$

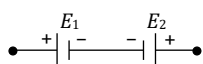

$$(E_1 - E_2) = xl_2$$

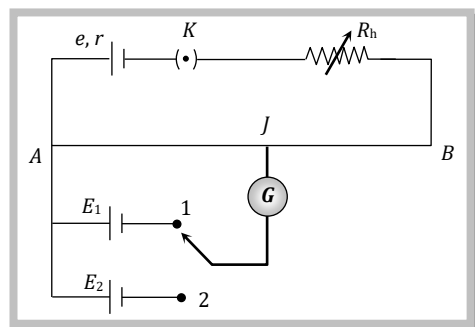

$$\Rightarrow \frac{E_1 + E_2}{E_1 - E_2} = \frac{l_1}{l_2} \quad \text{or} \quad \frac{E_1}{E_2} = \frac{l_1 + l_2}{l_1 - l_2}$$

(3) **Comparison of resistances** : Let the balancing length for resistance R_1 (when XY is connected) is l_1 and let balancing length for resistance $R_1 + R_2$ (when YZ is connected) is l_2 .

Then $iR_1 = xl_1$ and $i(R_1 + R_2) = xl_2$

$$\Rightarrow \frac{R_2}{R_1} = \frac{l_2 - l_1}{l_1}$$

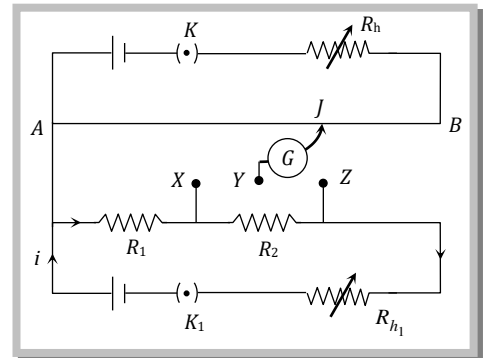

(4) **To determine thermo emf**

(i) The value of thermo-emf in a thermocouple for ordinary temperature difference is very low (10^{-6} volt). For this the potential gradient x must be also very low (10^{-4} V/m). Hence a high resistance (R) is connected in series with the potentiometer wire in order to reduce current.

(ii) The potential difference across R must be equal to the emf of standard cell *i.e.* $iR = E_0 \therefore i = \frac{E_0}{R}$

(iii) The small thermo emf produced in the thermocouple $e = xl$

(iv) $x = i\rho = \frac{iR}{L} \therefore e = \frac{iRl}{L}$ where L = length of potentiometer wire, ρ = resistance per unit length, l =

balancing length for e

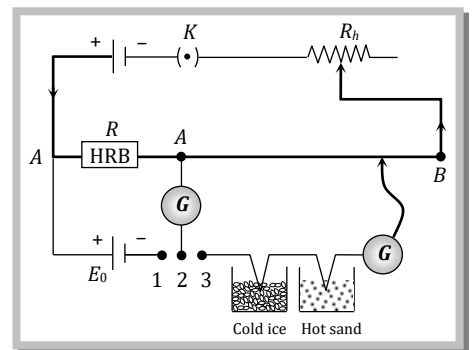

(5) **To calibrate ammeter and voltmeter**

Calibration of ammeter

(i) If p.d. across 1Ω resistance is measured by potentiometer, then current through this (indirectly measured) is thus known or if R is known then $i = V/R$ can be found.

(ii) Circuit and method

(a) Standardisation is required and performed as already described earlier. ($x = E_0/l_0$)

(b) The current through R or 1Ω coil is measured by the connected ammeter and same is calculated by potentiometer by finding a balancing length as described below.

Let i' current flows through 1Ω resistance giving p.d. as $V' = i'(1) = xl_1$ where l_1 is the balancing length. So error can be found as [i (measured by

$$\text{ammeter}) \Delta i = i - i' = xl_1 = \left(\frac{E_0}{l_0}\right)l_1]$$

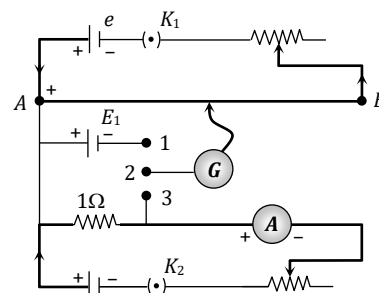

Calibration of voltmeter

(i) Practical voltmeters are not ideal, because these do not have infinite resistance. The error of such practical voltmeter can be found by comparing the voltmeter reading with calculated value of p.d. by potentiometer.

(ii) Circuit and procedure

(a) **Standardisation** : If l_0 is balancing length for E_0 the emf of standard cell by connecting 1 and 2 of bi-directional key, then $x = E_0/l_0$.

(b) The balancing length l_1 for unknown potential difference V is given by (by closing 2 and 3) $V' = xl_1 = (E_0/l_0)l_1$.

If the voltmeter reading is V then the error will be $(V - V')$ which may be $+ve$, $-ve$ or zero.

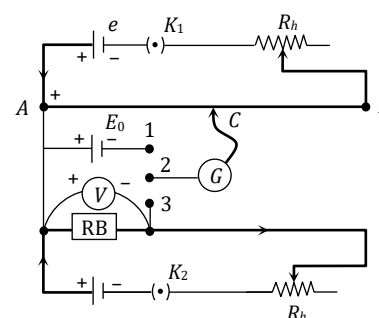

Concepts

☞ In case of zero deflection in the galvanometer current flows in the primary circuit of the potentiometer, not in the galvanometer circuit.

☞ A potentiometer can act as an ideal voltmeter.

Example

Example: 85 A battery with negligible internal resistance is connected with $10m$ long wire. A standard cell gets balanced on 600 cm length of this wire. On increasing the length of potentiometer wire by $2m$ then the null point will be displaced by

- (a) 200 cm (b) 120 cm (c) 720 cm (d) 600 cm

Solution : (b) By using $\frac{L_1}{L_2} = \frac{l_1}{l_2} \Rightarrow \frac{10}{12} = \frac{600}{l_2} \Rightarrow l_2 = 720\text{ cm}.$

Hence displacement = $720 - 600 = 120\text{ cm}$

Example: 86 In the following circuit a 10 m long potentiometer wire with resistance 1.2 ohm/m , a resistance R_1 and an accumulator of emf 2 V are connected in series. When the emf of thermocouple is 2.4 mV then the deflection in galvanometer is zero. The current supplied by the accumulator will be

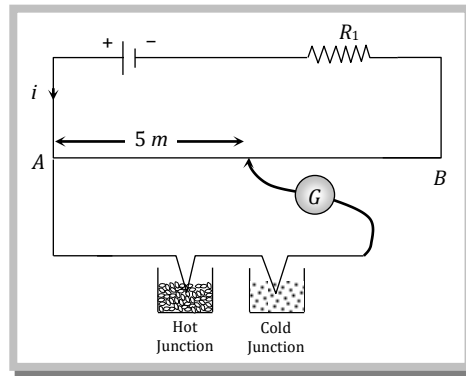

- (a) $4 \times 10^{-4} A$ (b) $8 \times 10^{-4} A$ (c) $4 \times 10^{-3} A$ (d) $8 \times 10^{-3} A$

Solution : (a) $E = x l = i \rho l$ $\therefore i = \frac{E}{\rho l} = \frac{E}{\rho l} = \frac{2.4 \times 10^{-3}}{1.2 \times 5} = 4 \times 10^{-4} A .$

Example: 87 The resistivity of a potentiometer wire is $40 \times 10^{-8} \Omega m$ and its area of cross section is $8 \times 10^{-6} m^2$. If 0.2 amp. Current is flowing through the wire, the potential gradient will be

- (a) 10^{-2} volt/m (b) 10^{-1} volt/m (c) $3.2 \times 10^{-2} \text{ volt/m}$ (d) 1 volt/m

Solution : (a) Potential gradient $= \frac{V}{L} = \frac{iR}{L} = \frac{i\rho L}{AL} = \frac{i\rho}{A} = \frac{0.2 \times 40 \times 10^{-8}}{8 \times 10^{-6}} = 10^{-2} V/m$

Example: 88 A deniel cell is balanced on 125 cm length of a potentiometer wire. When the cell is short circuited with a 2 Ω resistance the balancing length obtained is 100 cm. Internal resistance of the cell will be

- (a) 1.5 Ω (b) 0.5 Ω (c) 1.25 Ω (d) 4/5 Ω

Solution: (b) By using $r = \frac{l_1 - l_2}{l_2} \times R' \Rightarrow r = \frac{125 - 100}{100} \times 2 = \frac{1}{2} = 0.5 \Omega$

Example: 89 A potentiometer wire of length 10 m and a resistance 30 Ω is connected in series with a battery of emf 2.5 V and internal resistance 5 Ω and an external resistance R. If the fall of potential along the potentiometer wire is 50 $\mu V/mm$, the value of R is (in Ω)

- (a) 115 (b) 80 (c) 50 (d) 100

Solution : (a) By using $x = \frac{e}{(R + R_h + r)} \cdot \frac{R}{L}$
 $\Rightarrow \frac{50 \times 10^{-6}}{10^{-3}} = \frac{2.5}{(30 + R + 5)} \times \frac{30}{10} \Rightarrow R = 115$

Example: 90 A 2 volt battery, a 15 Ω resistor and a potentiometer of 100 cm length, all are connected in series. If the resistance of potentiometer wire is 5 Ω , then the potential gradient of the potentiometer wire is

- (a) 0.005 V/cm (b) 0.05 V/cm (c) 0.02 V/cm (d) 0.2 V/cm

Solution : (a) By using $x = \frac{e}{(R + R_h + r)} \cdot \frac{R}{L} \Rightarrow x = \frac{2}{(5 + 15 + 0)} \times \frac{5}{1} = 0.5 V/m = 0.005 V/cm$

Example: 91 In an experiment to measure the internal resistance of a cell by potentiometer, it is found that the balance point is at a length of 2 m when the cell is shunted by a 5 Ω resistance; and is at a length of 3 m when the cell is shunted by a 10 Ω resistance. The internal resistance of the cell is, then

- (a) 1.5 Ω (b) 10 Ω (c) 15 Ω (d) 1 Ω

Solution : (b) By using $r = \left(\frac{l_1 - l_2}{l_2}\right)R' \Rightarrow r = \left(\frac{l_1 - 2}{2}\right) \times 5$ (i)

and $r = \left(\frac{l_1 - 3}{3}\right) \times 10$ (ii)

On solving (i) and (ii) $r = 10 \Omega$

Example: 92 A resistance of 4Ω and a wire of length 5 metres and resistance 5Ω are joined in series and connected to a cell of emf 10 V and internal resistance 1Ω . A parallel combination of two identical cells is balanced across 300 cm of the wire. The emf E of each cell is

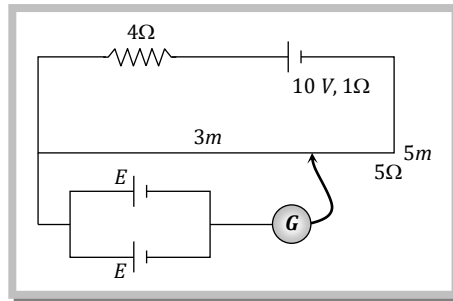

- (a) 1.5 V (b) 3.0 V (c) 0.67 V (d) 1.33 V

Solution : (b) By using $E_{eq} = \frac{e}{(R + R_h + r)} \cdot \frac{R}{L} \times l \Rightarrow E = \frac{10}{(5 + 4 + 1)} \times \frac{5}{5} \times 3 \Rightarrow E = 3 \text{ volt}$

Example: 93 A potentiometer has uniform potential gradient across it. Two cells connected in series (i) to support each other and (ii) to oppose each other are balanced over 6 m and 2 m respectively on the potentiometer wire. The emf's of the cells are in the ratio of

- (a) $1 : 2$ (b) $1 : 1$ (c) $3 : 1$ (d) $2 : 1$

Solution : (d) If suppose emf's of the cells are E_1 and E_2 respectively then

$$E_1 + E_2 = x \times 6 \quad \text{..... (i)} \quad [x = \text{potential gradient}]$$

and $E_1 - E_2 = x \times 2$ (ii)

$$\Rightarrow \frac{E_1 + E_2}{E_1 - E_2} = \frac{3}{1} \Rightarrow \frac{E_1}{E_2} = \frac{2}{1}$$

Example: 94 In the following circuit the potential difference between the points B and C is balanced against 40 cm length of potentiometer wire. In order to balance the potential difference between the points C and D , where should jockey be pressed

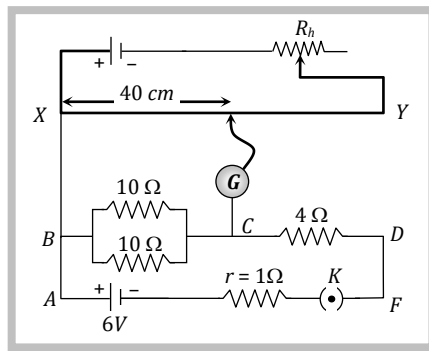

- (a) 32 cm (b) 16 cm (c) 8 cm (d) 4 cm

Solution : (a) $\frac{1}{R} = \frac{1}{10} + \frac{1}{10} = \frac{2}{10} = \frac{1}{5}$ or $R_1 = 5 \Omega$

$R_2 = 4\Omega, l_1 = 40 \text{ cm}, l_2 = ?$

$$l_2 = l_1 \frac{R_2}{R_1} \text{ or } l_2 = \frac{40 \times 4}{5} = 32 \text{ cm}$$

Example: 95 In the following circuit diagram fig. the lengths of the wires AB and BC are same but the radius of AB is three times that of BC . The ratio of potential gradients at AB and BC will be

- (a) 1 : 9
- (b) 9 : 1
- (c) 3 : 1
- (d) 1 : 3

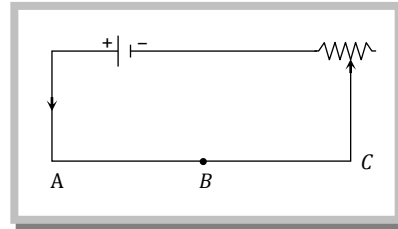

Solution : (a) $x \propto R_p \propto \frac{1}{r^2} \Rightarrow \frac{x_1}{x_2} = \frac{r_2^2}{r_1^2} = \left(\frac{r}{3r}\right)^2 = \frac{1}{9}$

Example: 96 With a certain cell the balance point is obtained at 0.60 m from one end of the potentiometer. With another cell whose emf differs from that of the first by 0.1 V , the balance point is obtained at 0.55 m . Then, the two emf's are

- (a) $1.2 \text{ V}, 1.1 \text{ V}$
- (b) $1.2 \text{ V}, 1.3 \text{ V}$
- (c) $-1.1 \text{ V}, -1.0 \text{ V}$
- (d) None of the above

Solution : (a) $E_1 = x(0.6)$ and $E_2 = E_1 - 0.1 = x(0.55) \Rightarrow \frac{E_1}{E_1 - 0.1} = \frac{0.6}{0.55}$

or $55 E_1 = 60 E_1 - 6 \Rightarrow E_1 = \frac{6}{5} = 1.2 \text{ V}$ thus $E_2 = 1.1 \text{ V}$

Example: 11

A cell of internal resistance 1.5Ω and of emf 1.5 volt balances 500 cm on a potentiometer wire. If a wire of 15Ω is connected between the balance point and the cell, then the balance point will shift

- (a) To zero
- (b) By 500 cm
- (c) By 750 cm
- (d) None of the above

Solution : (d) In balance condition no current flows in the galvanometer circuit. Hence there will be no shift in balance point after connecting a resistance between balance point and cell.

Assignment

Level-1

- A current of 1 mA is flowing through a copper wire. How many electrons will pass a given point in one second
[$e = 1.6 \times 10^{-19}\text{ coulomb}$]
(a) 6.25×10^{19} (b) 6.25×10^{15} (c) 6.25×10^{31} (d) 6.25×10^9
- The drift velocity of free electrons in a conductor is v when a current i is flowing in it. If both the radius and current are doubled, then drift velocity will be
(a) v (b) $\frac{v}{2}$ (c) $\frac{v}{4}$ (d) $\frac{v}{8}$
- Calculate the amount of charge flowing in 2 minutes in a wire of resistance $10\ \Omega$ when a potential difference of 20 V is applied between its ends
(a) 120 C (b) 240 C (c) 20 C (d) 4 C
- The drift velocity does not depend upon
(a) Cross-section of the wire (b) Length of the wire (c) Number of free electrons (d) Magnitude of the current
- If an electric current is passed through nerve the man
(a) Begins to laugh (b) Begins to Weep (c) Begins to excited (d) Becomes insensitive to pain
- For driving a current of 2 A for 6 minute in a circuit 1000 J of work is to be done. The emf of source in the circuit is
(a) 1.38 V (b) 13.8 V (c) 83.3 V (d) 8.3 V
- A solenoid is at potential difference 60 V and current flows through it is 15 ampere , then the resistance of coil will be
(a) $4\ \Omega$ (b) $8\ \Omega$ (c) $0.25\ \Omega$ (d) $2\ \Omega$
If a power of 100 watt is being supplied across a potential difference of 200 V , current flowing is
(a) 2 A (b) 0.5 A (c) 1 A (d) 20 A
- In a conductor 4 coulombs of charge flows for 2 seconds . The value of electric current will be
(a) 4 volts (b) 4 amperes (c) 2 amperes (d) 2 volts
- 62.5×10^{18} electrons per second are flowing through a wire of area of cross-section 0.1 m^2 , the value of current flowing will be
(a) 1 A (b) 0.1 A (c) 10 A (d) 0.11 A
- When there is an electric current through a wire along its length, then as electric field must exist
(a) Out side the wire but normal to it (b) Outside the wire but parallel to it
(c) Inside the wire but parallel to it (d) Inside the wire but normal to it

Level-2

12. A current i is passing through a wire having two sections P and Q of uniform diameters d and $d/2$ respectively. If the mean drift velocity of electrons in sections P and Q is denoted by v_P and v_Q respectively, then

- (a) $V_P = V_Q$ (b) $V_P = \frac{1}{2} V_Q$ (c) $V_P = \frac{1}{4} V_Q$ (d) $V_P = 2V_Q$

13. A steady current flows in a metallic conductor of non-uniform cross-section. The quantities/quantity constant along the length of the conductor is/are

- (a) Current, electric field and drift velocity (b) Drift speed only
(c) Current and drift speed (d) Current only

14. We are able to obtain fairly large currents in a conductor because

- (a) The electron drift speed is usually very large
(b) The number density of free electrons is very high and this can compensate for the low values of the electron drift speed and the very small magnitude of the electron charge
(c) The number density of free electrons as well as the electron drift speeds are very large and these compensate for the very small magnitude of the electron charge
(d) The very small magnitude of the electron charge has to be divided by the still smaller product of the number density and drift speed to get the electric current

15. The electric current passing through a metallic wire produces heat because of

- (a) Collisions of conduction electrons with each other
(b) Collisions of the atoms of the metal with each other
(c) The energy released in the ionization of the atoms of the metal
(d) Collisions of the conduction electrons with the atoms of the metallic wire

16. An ionization chamber with parallel conducting plates as anode and cathode has 5×10^7 electrons and the same number of singly-charged positive ions per cm^3 . The electrons are moving at 0.4 m/s . The current density from anode to cathode is $4 \mu A/m^2$. The velocity of positive ions moving towards cathode is

- (a) 0.4 m/s (b) 1.6 m/s (c) Zero (d) 0.1 m/s

17. A wire of resistance 5Ω is connected to a battery whose emf is 2 V and internal resistance 1Ω . In 2 minutes, the energy transferred from chemical to electric form is 80 J . Then

- (a) Energy appearing as *Joule* heat in the wire is 80 J
(b) Energy appearing as *Joule* heat in the wire is 40 J
(c) 80 J are used to heat the wire and battery in equal proportion
(d) Due to internal resistance of battery, rate of *Joule*, heating in wire is about 67 J

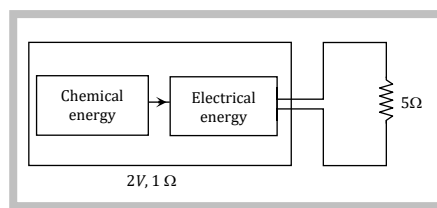

18. A beam of electron is emitted from filament and accelerated by an electric field as shown in figure. The two stops at the left ensure that the electric beam has uniform cross-section

- (a) The speed of the electron is more at B than at A
(b) The electric current is from left to right
(c) The magnitude of the current is larger at B than at A
(d) The current density is more at B than at A

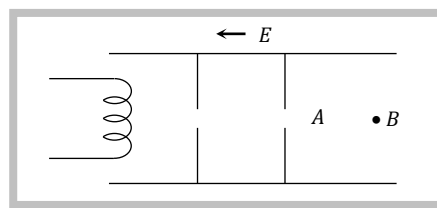

19. Following figure shows four situations in which positive and negative charges moves horizontally through a region and gives the rate at which each charge moves. Rank the situations according to the effective current through the region greatest first

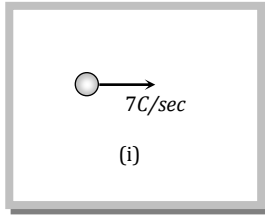

(i)

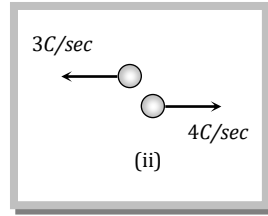

(ii)

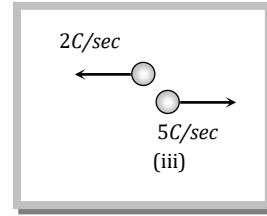

(iii)

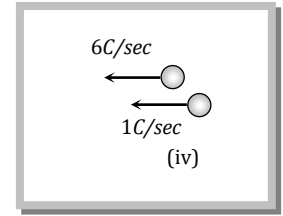

(iv)

(a) $i = ii = iii = iv$

(b) $i > ii > iii > iv$

(c) $i = ii = iii > iv$

(d) $i = ii = iii < iv$

20. A straight conductor of uniform cross-section carries a current i . Let s = specific charge of an electron. The momentum of all the free electrons per unit length of the conductor, due to their drift velocities only is

(a) is

(b) $\frac{i}{s}$

(c) $\sqrt{\frac{i}{s}}$

(d) $\left(\frac{i}{s}\right)^2$

21. The figure here shows a portion of a circuit. What are the magnitude and direction of the current in the lower right hand wire

(a) 8A, left ward

(b) 8A, right ward

(c) 9A right ward

(d) 9A, left ward

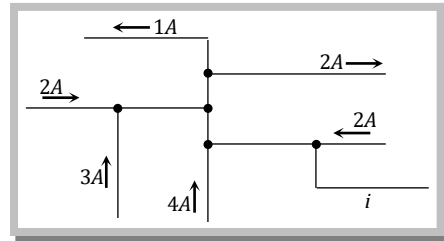

Level-1

22. The electric resistance of a certain wire of iron is R . If its length and radius are both doubled, then

(a) The resistance will be halved and the specific resistance will be doubled

(b) The resistance and the specific resistance, will both remain unchanged

(c) The resistance will be doubled and the specific resistance will be halved

(d) The resistance will be halved and the specific resistance will remain unchanged

23. The thermistor are usually made of

(a) Metal oxides with high temperature coefficient of resistivity

(b) Metals with high temperature coefficient of resistivity

(c) Metals with low temperature coefficient of resistivity

(d) Semiconducting materials having low temperature coefficient of resistivity

24. A wire of length L is drawn such that it's diameter is reduced to half of it's original diameter. If the initial resistance of the wire were 10Ω . It's new resistance would be

(a) 40Ω (b) 80Ω (c) 120Ω (d) 160Ω

25. Fuse wire is a wire of

(a) High resistance and low melting point

(b) Low resistance and low melting point

(c) Low resistance and high melting point

(d) High resistance and high melting point

26. The length of a given cylindrical wire is increased by 100%. Due to the consequent decrease in diameter the change in the resistance of the wire will be

(a) 300 %

(b) 200 %

(c) 100 %

(d) 50 %

27. At ordinary temperatures, the electrical conductivity of semi-conductors in mho/meter is in the range

(a) 10^3 to 10^{-4} (b) 10^6 to 10^9 (c) 10^{-6} to 10^{-10} (d) 10^{-10} to 10^{-16}

28. The resistance of a wire of length l is R . the wire is stretched to increase its length to $4l$. The resistance of the wire will become

- (a) $16R$ (b) $\frac{R}{4}$ (c) $\frac{R}{16}$ (d) $4R$
29. We have two wires A and B of same mass and same material. The diameter of the wire A is half of that B . If the resistance of wire A is 24 ohm then the resistance of wire B will be
 (a) 12 ohm (b) 3.0 ohm (c) 1.5 ohm (d) None of these
30. A fuse wire with radius 1 mm blows at 1.5 ampere . The radius of the fuse wire of the same material to blow at $3A$ will be
 (a) $4^{1/3}\text{ mm}$ (b) $3^{1/4}\text{ mm}$ (c) $2^{1/3}\text{ mm}$ (d) $3^{1/2}\text{ mm}$
31. A strip of copper and another of germanium are cooled from room temperature to 80 K . The resistance of
 (a) Each of these increases
 (b) Each of these decreases
 (c) Copper strip increases and that of germanium decreases
 (d) Copper strip decreases and that of germanium increases
32. A carbon resistance is having a following coding green, orange, black, gold. The resistance of resistor is
 (a) $53 \times 10^0 \pm 5\%$ (b) $53 \times 10^1 \pm 5\%$ (c) $53 \times 10^0 \pm 10\%$ (d) $53 \times 10 \pm 10\%$
33. A wire of radius r has resistance R . If it is stretched to a radius of $\frac{3r}{4}$, its resistance becomes
 (a) $\frac{9R}{16}$ (b) $\frac{15R}{9}$ (c) $\frac{81R}{256}$ (d) $\frac{256R}{81}$
34. The resistance of a conductor increases with
 (a) Increase in length (b) Increase in temperature (c) Decrease in cross-section (d) All of these
35. A uniform resistance wire of length L and diameter d has a resistance R . Another wire of same material has length $4L$ and diameter $2d$, the resistance will be
 (a) $2R$ (b) R (c) $\frac{R}{2}$ (d) $\frac{R}{4}$
36. By increasing the temperature, the specific resistance of a conductor and semiconductor
 (a) Increases for both (b) Decreases for both (c) Increases, decreases (d) Decreases for both
37. The resistance of an incandescent lamp is
 (a) Greater when switched off (b) Smaller when switched on
 (c) The same whether it is switched off or switched on (d) None of these
38. A wire of length 100 cm is connected to a cell of emf 2 V and negligible internal resistance. The resistance of the wire is 3Ω . The additional resistance required to produce a potential drop of $1\text{ milli volt per cm}$ is
 (a) 60Ω (b) 47Ω (c) 57Ω (d) 35Ω
39. Which of the following does not obey Ohm's law
 (a) Copper (b) Aluminium (c) Diode-valve (d) None of these
40. If a wire of resistance R is melted and recasted to half of its length, then the new resistance of the wire will be
 (a) $R/4$ (b) $R/2$ (c) R (d) $2R$
41. The resistance of a wire is R . If the length of the wire is doubled by stretching, then the new resistance will be
 (a) $2R$ (b) $4R$ (c) R (d) $\frac{R}{4}$
42. A uniform wire of resistance R is uniformly compressed along its length, until its radius becomes n times the original radius. New resistance of the wire becomes

- (a) $\frac{R}{n^4}$ (b) $\frac{R}{n^2}$ (c) $\frac{R}{n}$ (d) nR

43. At what temperature will the resistance of a copper wire become three times its value at 0°C ? (Temperature coefficient of resistance for copper = 4×10^{-3} per $^\circ\text{C}$)

- (a) 400°C (b) 450°C (c) 500°C (d) 550°C

44. The resistance of a conductor is 5 ohm at 50°C and 6 ohm at 100°C . Its resistance at 0°C is

- (a) 1 ohm (b) 2 ohm (c) 3 ohm (d) 4 ohm

45. The lead wires should have

- (a) Larger diameter and low resistance (b) Smaller diameter and high resistance
(c) Smaller diameter and low resistance (d) Larger diameter and high resistance

46. Identify the set in which all the three materials are good conductor of electricity

- (a) *Cu, Ag, Au* (b) *Cu, Si, Diamond* (c) *Cu, Hg, NaCl* (d) *Cu, Ge, Hg*

47. When a piece of aluminium wire finite length is drawn through a series of dies to reduce its diameter to half its original value, its resistance will become

- (a) Two times (b) Four times (c) Eight times (d) Sixteen times

48. The resistance of a coil is $4.2\ \Omega$ at 100°C and the temperature coefficient of resistance of its material is $0.004/^\circ\text{C}$. Its resistance at 0°C is

- (a) $6.5\ \Omega$ (b) $5\ \Omega$ (c) $3\ \Omega$ (d) $4\ \Omega$

49. The resistivity of a wire depends on its

- (a) Length (b) Area of cross-section (c) Shape (d) Material

50. Two wires *A* and *B* of same material and same mass have radius $2r$ and r . If resistance of wire *A* is $34\ \Omega$, then resistance of *B* will be

- (a) $544\ \Omega$ (b) $272\ \Omega$ (c) $68\ \Omega$ (d) $17\ \Omega$

51. When a potential difference is applied across the ends of a linear metallic conductor

- (a) The free electrons are accelerated continuously from the lower potential end to higher potential end
(b) The free electrons are accelerated continuously from the higher potential end to lower potential end
(c) The free electrons acquire a constant drift velocity from the lower potential end to the higher potential end
(d) The free electrons are set in motion from their position of rest

52. For a metallic wire, the ratio V/i (V = the applied potential difference, i = current flowing) is

- (a) Independent of temperature
(b) Increases as the temperature rises
(c) Decreases as the temperature rises
(d) Increases or decreases as temperature rises, depending upon the metal

53. If the resistivity of a potentiometer wire be ρ and area of cross-section be A , then what will be potential gradient along the wire

- (a) $\frac{i\rho}{A}$ (b) $\frac{i}{A\rho}$ (c) $\frac{iA}{\rho}$ (d) $iA\rho$

54. A wire of 50 cm long and 1 mm^2 in cross-sectional area carries a current 4 A when connected to a 2 V battery. The resistivity of the wire is

- (a) $2 \times 10^{-7}\ \Omega\text{m}$ (b) $5 \times 10^{-7}\ \Omega\text{m}$ (c) $4 \times 10^{-6}\ \Omega\text{m}$ (d) $1 \times 10^{-6}\ \Omega\text{m}$

55. A metal wire of specific resistance $64 \times 10^{-6}\ \Omega\text{cm}$ and length 198 cm has resistance of $7\ \Omega$. The radius of the wire will be

- (a) 2.4 cm (b) 0.24 cm (c) 0.024 cm (d) 24 cm

56. Two wires of the same material are given. The first wire is twice as long as the second and has twice the diameter of the second. The resistance of the first will be

- (a) Twice of the second (b) Half of the second (c) Equal to the second (d) Four times of the second

57. There is a current of 1.344 amp in a copper wire whose area of cross-section normal to the length of the wire is 1 mm^2 . If the number of free electrons per cm^3 is 8.4×10^{22} , then the drift velocity would be
 (a) 1.0 mm/sec (b) 1.0 m/sec (c) 0.1 mm/sec (d) 0.01 mm/sec
58. A battery of 6 volts is connected to the terminals of a three metre long wire of uniform thickness and resistance of the order 100Ω . The difference of potential between two points separated by 50 cm on the wire will be
 (a) 1 V (b) 1.5 V (c) 2 V (d) 3 V
59. The resistance of 20 cm long wire is 5 ohm . The wire is stretched to a uniform wire of 40 cm length. The resistance now will be (in ohms)
 (a) 5 (b) 10 (c) 20 (d) 200
60. A minimum resistance is to be prepared from a copper wire, its length and diameter should be
 (a) l and d (b) $2l$ and d (c) $l/2$ and $2d$ (d) $2l$ and $d/2$
61. The specific resistance of a wire is ρ , its volume is 3 m^3 and its resistance is 3 ohms , then its length will be
 (a) $\sqrt{\frac{1}{\rho}}$ (b) $\frac{3}{\sqrt{\rho}}$ (c) $\frac{1}{\rho} \sqrt{3}$ (d) $\rho \sqrt{\frac{1}{3}}$

62. Value of resistance shown in the figure is

- (a) 1500 mega ohms
 (b) 150 mega ohms
 (c) 15000 mega ohms
 (d) 15 mega ohms

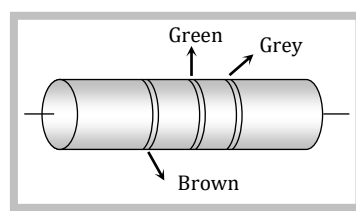

63. Read the following statements carefully

Y: The resistivity of a semiconductor decreases with increase of temperature

Z: In a conducting solid, rate of collisions between free electrons and ions increases with increases of temperature

Select the correct statements (s) from the following

- (a) Y is true but Z is false (b) Y is false but Z is true
 (c) Both Y and Z are true (d) Y is true and Z is the correct reason for Y

64. The figure shows three cylindrical copper conductors along with their face areas and lengths. Rank them according to the current through them greatest first. When the same potential difference V is applied across their length

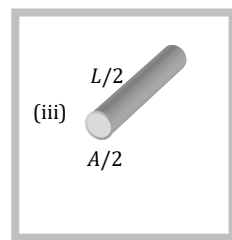
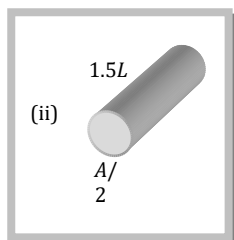
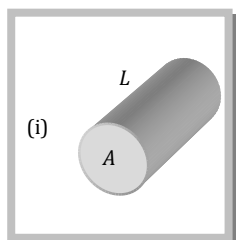

- (a) (i) > (ii) > (iii) (b) (i) < (ii) < (iii) (c) (ii) > (iii) > (i) (d) (i) > (iii) > (ii)

Level-2

65. Express which of the following setups can be used to verify Ohm's law

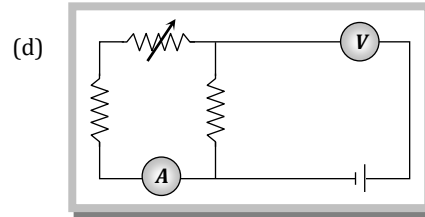
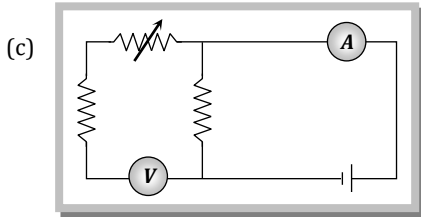
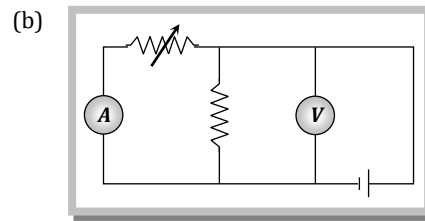
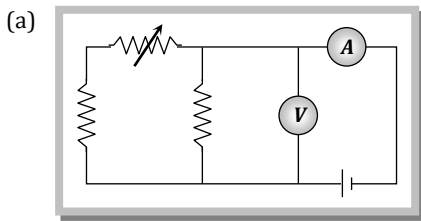

66. A rod of a certain metal is 1.0 m long and 0.6 cm in diameter. Its resistance is $3 \times 10^{-3}\ \Omega$. Another disc made of same metal is 2.0 cm in diameter and 1.00 mm in thick. What is the resistance between the round faces of the disc

- (a) $1.35 \times 10^{-8}\ \Omega$ (b) $2.7 \times 10^{-7}\ \Omega$ (c) $4.05 \times 10^{-6}\ \Omega$ (d) $8.1 \times 10^{-5}\ \Omega$

67. Two wires of brass of diameter 1 mm and 2 mm have equal weight. Their electrical resistance will be in the ratio

- (a) 16 : 1 (b) 1 : 16 (c) 1 : 4 (d) 4 : 1

68. The resistance of a wire of iron is 10 ohms and temperature coefficient of resistivity is $5 \times 10^{-3}/^\circ\text{C}$. At 20°C it carries 30 milliamperes of current. Keeping constant potential difference between its ends, the temperature of the wire is raised to 120°C . The current in *milliamperes* that flows in the wire is

- (a) 20 (b) 15 (c) 10 (d) 40

69. Resistances AB and CD are connected in a circuit in which current is flowing. The positions of A, B, C and D points are kept such that no current flows through the resistance AB and CD . If AB and CD are connected with EF then

- (a) No current will flows in EF
 (b) Current will flow from F to E
 (c) Current will flow from E to F and the potential of E will be equal to that of A or B
 (d) Current will flow from E to F and the potential of E is less than the potential of A or B

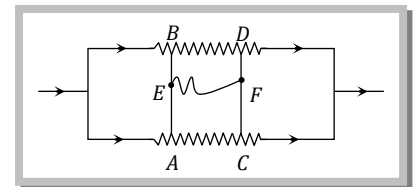

70. In an experiment, a graph was plotted of the potential difference V between the terminals of a cell against the circuit current i by varying load rheostat. Internal conductance of the cell is given by

- (a) xy
 (b) $\frac{y}{x}$
 (c) $\frac{x}{y}$
 (d) $(x - y)$

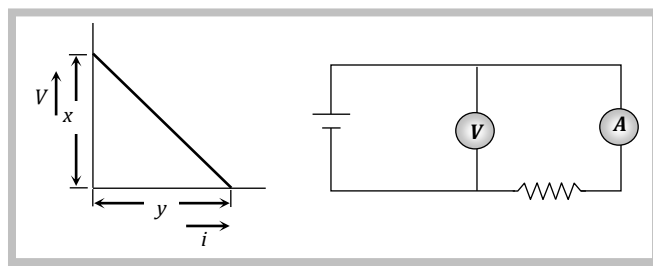

71. An aluminium rod and a copper rod are taken such that their lengths are same and their resistances are also same. The specific resistance of copper is half that of aluminium, but its density is three times that of aluminium. The ratio of the mass of aluminum rod and that of copper rod will be

- (a) $\frac{1}{6}$ (b) $\frac{2}{3}$ (c) $\frac{1}{3}$ (d) 6

72. All the edges of a block with parallel faces are unequal. Its longest edge is twice its shortest edge. The ratio of the maximum to minimum resistance between parallel faces is

- (a) 2 (b) 4
 (c) 8 (d) Indeterminate unless the length of the third edge is specified

73. The resistivity of the materials used for making the block shown along with is $5 \times 10^{-5} \text{ ohm-m}$. The ratio of the resistances across faces $ABCD$ and $EFGH$ to that across faces $AEHD$ and $BFGC$ is

- (a) 1 : 1
- (b) 10 : 1
- (c) 1 : 100
- (d) 100 : 1

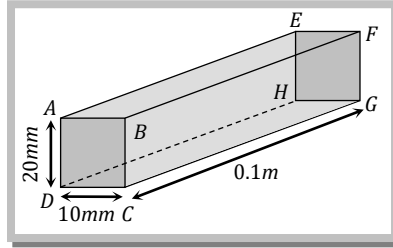

74. A and B are two square plates of same metal and same thickness but length of B is twice that of A . Ratio of resistances of A and B is

- (a) 4 : 1
- (b) 1 : 4
- (c) 1 : 1
- (d) 1 : 2

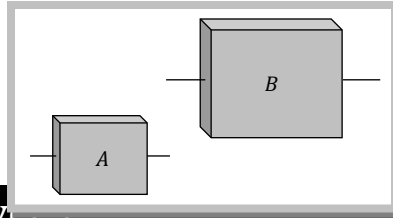

Level 1

75. A wire has a resistance of 6Ω . It is cut into two parts and both half values are connected in parallel. The new resistance is

- (a) 6Ω
- (b) 3Ω
- (c) 1.5Ω
- (d) 12Ω

76. An electric current is passed through a circuit containing two wires of the same material, connected in parallel. If the lengths and radii of the wires are in the ratio of $\frac{4}{3}$ and $\frac{2}{3}$, then the ratio of the currents passing through the wires will be

- (a) $8/9$
- (b) $1/3$
- (c) 3
- (d) 2

77. The total current supplied to the circuit by the battery is

- (a) 4 A
- (b) 2 A
- (c) 1 A
- (d) 6 A

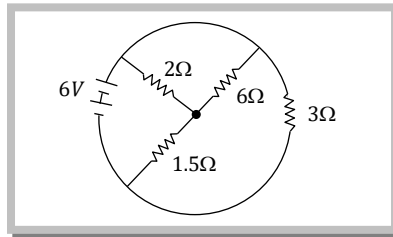

78. Resistances n , each of $r \text{ ohm}$, when connected in parallel give an equivalent resistance of $R \text{ ohm}$. If these resistances were connected in series, the combination would have a resistance in ohms , equal to

- (a) R/n
- (b) nR
- (c) n^2R
- (d) R/n^2

79. A 3 volt battery with negligible internal resistance is connected in a circuit as shown in the figure. The current, i , in the circuit will be

- (a) $1/3 \text{ A}$
- (b) 1 A
- (c) 1.5 A
- (d) 2 A

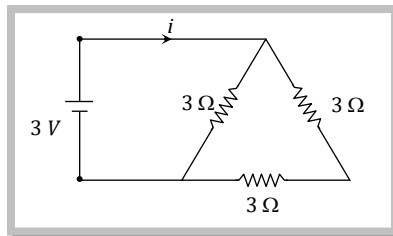

80. In a Wheatstone's bridge all the four arms have equal resistance R . If the resistance of the galvanometer arm is also R , the equivalent resistance of the combination as seen by the battery is

- (a) $\frac{R}{2}$
- (b) R
- (c) $2R$
- (d) $\frac{R}{4}$

81. The equivalent resistance of the following diagram between A and B is

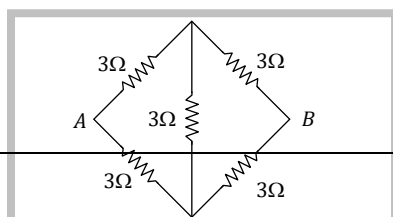

- (a) $\frac{2}{4} \Omega$
 (b) 9Ω
 (c) 6Ω
 (d) None of these

82. Two wires of the same dimensions but resistivities ρ_1 and ρ_2 are connected in series. The equivalent resistivity of the combination is

- (a) $\rho_1 + \rho_2$ (b) $\frac{\rho_1 + \rho_2}{2}$ (c) $\sqrt{\rho_1 \rho_2}$ (d) $2(\rho_1 + \rho_2)$

83. The potential difference between point A and B is

- (a) $\frac{20}{7} V$
 (b) $\frac{40}{7} V$
 (c) $\frac{10}{7} V$
 (d) 0

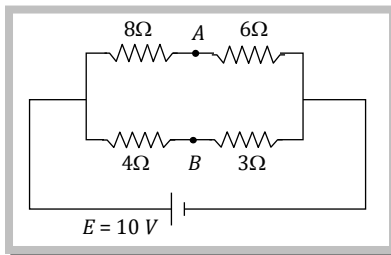

84. Three resistors are connected to form the sides of a triangle ABC, the resistance of the sides AB, BC and CA are 40 ohms; 60 ohms and 100 ohms respectively. The effective resistance between the points A and B in ohms will be

- (a) 32 (b) 64 (c) 50 (d) 200

85. In the circuit shown below, what is the value of unknown resistance R so that the total resistance between P and Q is also equal to R

- (a) 3Ω
 (b) $\sqrt{39} \Omega$
 (c) $\sqrt{69} \Omega$
 (d) 10Ω

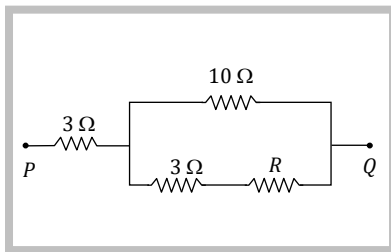

86. A uniform wire of resistance 9Ω is cut into 3 equal parts. They are connected in the form of equilateral triangle ABC. A cell of emf 2V and negligible internal resistance is connected across B and C. Potential difference across AB is

- (a) 1V (b) 2V (c) 3V (d) 0.5V

In the given circuit it is observed that the current i is independent of the value of the resistance R_6 . Then the resistance values must satisfy

- (a) $R_1 R_2 R_5 = R_3 R_4 R_6$
 (b) $\frac{1}{R_5} + \frac{1}{R_6} + \frac{1}{R_1 + R_2} + \frac{1}{R_3 + R_4}$
 (c) $R_1 R_4 = R_2 R_3$
 (d) $R_1 R_3 = R_2 R_4$

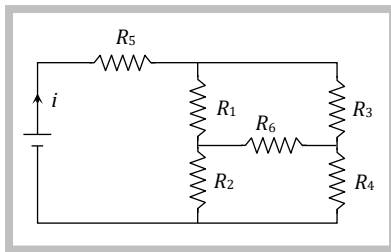

Two resistance wires on joining in parallel, the resultant resistance is $\frac{6}{5} \Omega$. One of the wire breaks. The effective resistance is 2Ω . The resistance of the brokes wire was

- (a) $\frac{3}{5} \Omega$ (b) 2Ω (c) $\frac{6}{5} \Omega$ (d) 3Ω

89. AB is a wire of uniform resistance. The galvanometer G shows no current when the length AC = 20 cm and CB = 80 cm. The resistance R is equal to

- (a) 2Ω

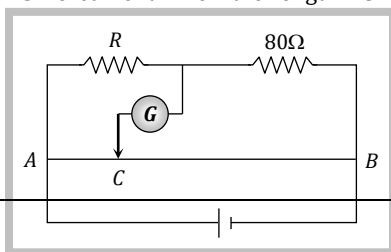

- (b) 8Ω
- (c) 20Ω
- (d) 40Ω

90. In the following figure potential difference between A and B is

- (a) 0
- (b) 5 volt
- (c) 10 volt
- (d) 15 volt

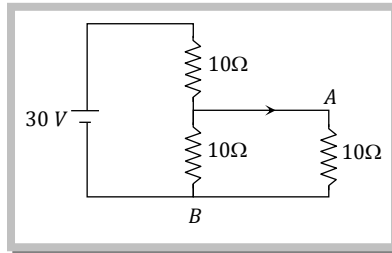

91. In the circuit shown in figure, the current drawn from the battery is 4 A. If 10Ω resistor is replaced by 20Ω resistor, the current further drawn from the circuit will be

- (a) 1 A
- (b) 2 A
- (c) 3 A
- (d) 0 A

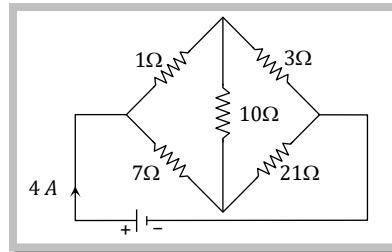

92. In the following figure current flowing through BD is

- (a) 0
- (b) 0.033 A
- (c) 0.066 A
- (d) None of these

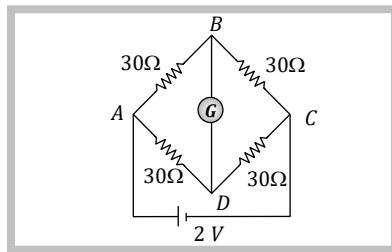

93. The resistors of resistances 2Ω , 4Ω and 8Ω are connected in parallel, then the equivalent resistance of the combination will be

- (a) $\frac{8}{7} \Omega$
- (b) $\frac{7}{8} \Omega$
- (c) $\frac{7}{4} \Omega$
- (d) $\frac{4}{9} \Omega$

94. Two resistance r_1 and r_2 ($r_1 < r_2$) are connected in parallel. Their equivalent resistance R is

- (a) $R < r_1$
- (b) $r_1 < R < r_2$
- (c) $r_2 < R < (r_1 + r_2)$
- (d) $R > (r_1 + r_2)$

95. Three resistances R , $2R$ and $3R$ are connected in parallel to a battery. Then

- (a) The current through each resistance is same
- (b) The potential drop across resistance $2R$ is maximum
- (c) The heat developed in resistance $3R$ is maximum
- (d) The heat developed in resistance R is maximum

96. Two wires of equal diameters of resistivity ρ_1 , ρ_2 and length x_1 , x_2 respectively are joined in series. The equivalent resistivity is

- (a) $\frac{\rho_1 x_1 + \rho_2 x_2}{x_1 + x_2}$
- (b) $\frac{\rho_1 x_1 - \rho_2 x_2}{x_1 - x_2}$
- (c) $\frac{\rho_1 x_2 + \rho_2 x_2}{x_1 + x_2}$
- (d) $\frac{\rho_1 x_1 - \rho_2 x_2}{x_1 - x_2}$

97. 10 wires (same length, same area, same material) are connected in parallel and each has 1Ω resistance, then the equivalent resistance will be

- (a) 10Ω
- (b) 1Ω
- (c) 0.1Ω
- (d) 0.001Ω

98. A wire of resistance R is cut into 'n' equal parts. These parts are then connected in parallel. The equivalent resistance of the combination will be

- (a) nR
- (b) $\frac{R}{n}$
- (c) $\frac{n}{R}$
- (d) $\frac{R}{n^2}$

99. What is the current (i) in the circuit as shown in figure

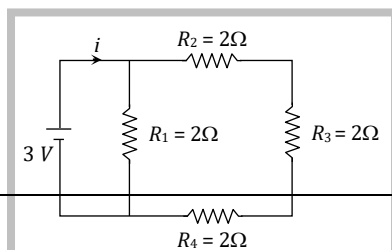

- (a) 2 A
- (b) 1.2 A
- (c) 1 A
- (d) 0.5 A

100. In the given figure, when galvanometer shows no deflection, the current (in ampere) flowing through $5\ \Omega$ resistance will be

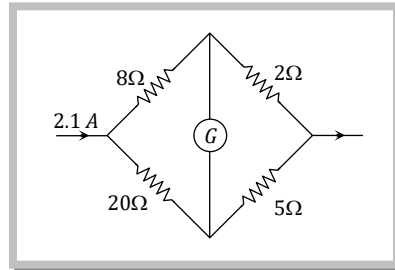

- (a) 0.5
- (b) 0.6
- (c) 0.9
- (d) 1.5

101. There is no current in $2\ \Omega$ resistance, then the equivalent resistance of the given circuit is

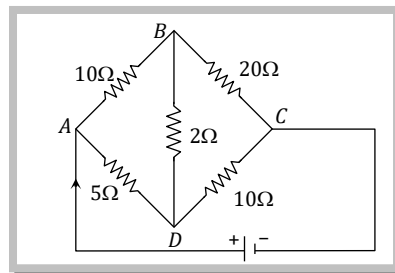

- (a) $10\ \Omega$
- (b) $\frac{30}{10}\ \Omega$
- (c) $\frac{13}{7}\ \Omega$
- (d) $\frac{7}{13}\ \Omega$

102. A copper wire of resistance R is cut into ten parts of equal length. Two pieces each are joined in series and then five such combinations are joined in parallel. The new combination will have a resistance

- (a) R
- (b) $\frac{R}{4}$
- (c) $\frac{R}{5}$
- (d) $\frac{R}{25}$

103. A student has 10 resistors of resistance ' r '. The minimum resistance made by him from given resistors is

- (a) $10r$
- (b) $\frac{r}{10}$
- (c) $\frac{r}{100}$
- (d) $\frac{r}{5}$

104. In the figure give below, the current passing through $6\ \Omega$ resistor is

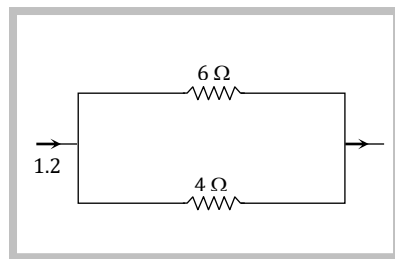

- (a) 0.40 amp
- (b) 0.48 amp
- (c) 0.72 amp
- (d) 0.90 amp

105. A uniform wire of $16\ \Omega$ resistance is made into the form of a square. Two opposite corners of the square are connected by a wire of resistance $16\ \Omega$. The effective resistance between the other two opposite corners is

- (a) $32\ \Omega$
- (b) $16\ \Omega$
- (c) $8\ \Omega$
- (d) $4\ \Omega$

106. A resistor of $0.5\ \Omega$ is connected to another resistor in parallel combination to get an equivalent resistance of $0.1\ \Omega$. The resistance of the second resistor is

- (a) $8\ \Omega$
- (b) $\frac{1}{8}\ \Omega$
- (c) $0.6\ \Omega$
- (d) $0.2\ \Omega$

107. Four wires AB, BC, CD, DA of resistance $4\ \text{ohm}$ each and a fifth wire BD of resistance $8\ \text{ohm}$ are joined to form a rectangle $ABCD$ of which BD is a diagonal. The effective resistance between the points A and B is

- (a) $24\ \text{ohm}$
- (b) $16\ \text{ohm}$
- (c) $\frac{4}{3}\ \text{ohm}$
- (d) $\frac{8}{3}\ \text{ohm}$

108. n equal resistors are first connected in series and then connected in parallel. What is the ratio of the maximum to the minimum resistance

- (a) n (b) $\frac{1}{n^2}$ (c) n^2 (d) $\frac{1}{n}$

109. Four resistances are connected in a circuit in the given figure. The electric current flowing through 4 ohm and 6 ohm resistance is respectively

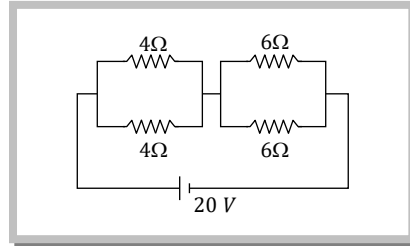

- (a) 2 amp and 4 amp
 (b) 1 amp and 2 amp
 (c) 1 amp and 1 amp
 (d) 2 amp and 2 amp

110. The potential difference between points A and B of adjoining figure is

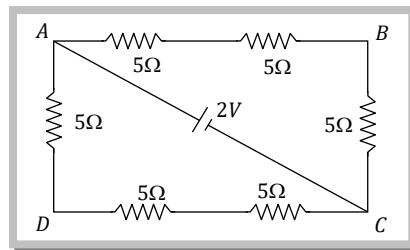

- (a) $\frac{2}{3} V$
 (b) $\frac{8}{9} V$
 (c) $\frac{4}{3} V$
 (d) 2 V

111. Resistances of 6 ohm each are connected in the manner shown in adjoining figure. With the current 0.5 ampere as shown in figure, the potential difference $V_P - V_Q$ is

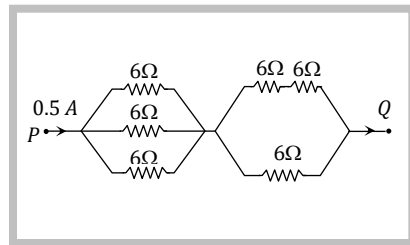

- (a) 3.6 V
 (b) 6.0 V
 (c) 3.0 V
 (d) 7.2 V

112. The current from the battery in circuit diagram shown is

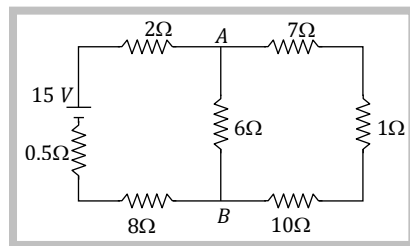

- (a) 1 A
 (b) 2 A
 (c) 1.5 A
 (d) 3 A

113. In the given figure, when key k is opened, the reading of the ammeter A will be

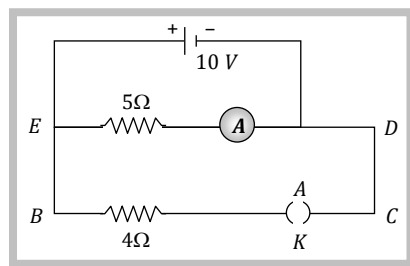

- (a) 50 A
 (b) 2 A
 (c) 0.5 A
 (d) $\frac{10}{9} A$

114. Two resistors are connected (a) in series (b) in parallel. The equivalent resistance in the two cases are 9 ohm and 2 ohm respectively. Then the resistances of the component resistors are

(a) 2 ohm and 7 ohm

(b) 3 ohm and 6 ohm

(c) 3 ohm and 9 ohm

(d) 5 ohm and 4 ohm

115. If the equivalent resistance between the points A and B in the following circuit is 5Ω , then the value of R will

- (a) 5Ω
- (b) 7Ω
- (c) 9Ω
- (d) 11Ω

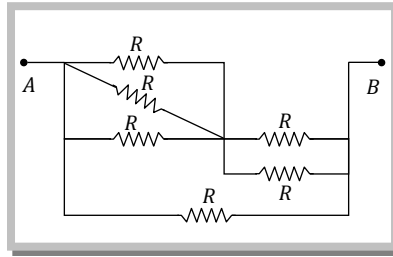

Level-2

116. Six equal resistance are connected between point P , Q and R as shown in the figure. Then the net resistance will be maximum between

- (a) P and Q
- (b) Q and R
- (c) P and R
- (d) Any two points

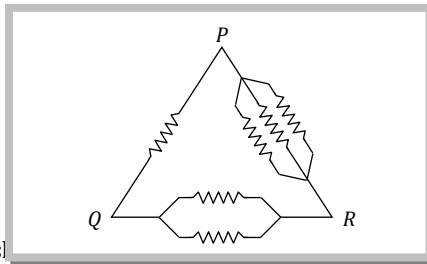

117. Five equal resistances each of resistance R are connected as shown in the figure. The current flowing in $AFCEB$ will be

- (a) $\frac{V}{2R}$
- (b) $\frac{2V}{R}$
- (c) $\frac{3V}{R}$
- (d) $\frac{V}{R}$

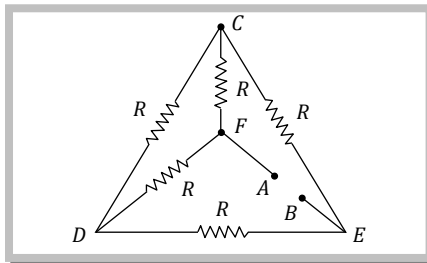

118. The resistance of the series combination of two resistances is S . When they are joined in parallel the total resistance is P . If $S = n P$ then the Minimum possible value of n is

- (a) 2
- (b) 3
- (c) 4
- (d) 1

119. The three resistance of equal value are arranged in the different combinations shown below. Arrange them in increasing order of power dissipation

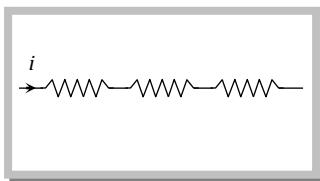

(I)

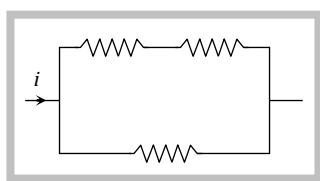

(II)

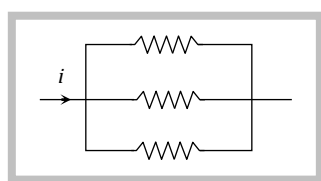

(III)

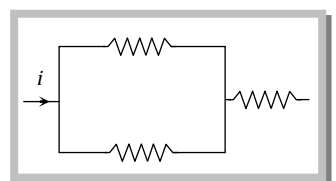

(IV)

- (a) $\text{III} < \text{II} < \text{IV} < \text{I}$
- (b) $\text{II} < \text{III} < \text{IV} < \text{I}$
- (c) $\text{I} < \text{IV} < \text{III} < \text{II}$
- (d) $\text{I} < \text{III} < \text{II} < \text{IV}$

120. In a typical Wheatstone network the resistances in cyclic order are $A = 10 \Omega$, $B = 10 \Omega$, $C = 4 \Omega$ and $D = 4 \Omega$. For the bridge to be balanced

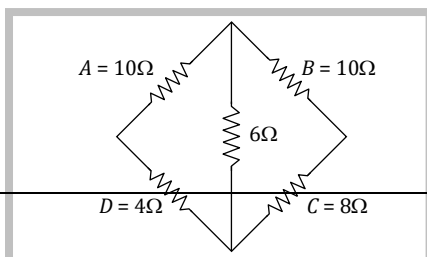

- (a) $10\ \Omega$ should be connected in parallel with A
- (b) $10\ \Omega$ should be connected in series with A
- (c) $5\ \Omega$ should be connected in series with B
- (d) $5\ \Omega$ should be connected in parallel with B

121. If in the circuit shown, the internal resistance of the battery is $1.5\ \Omega$ and V_P and V_Q are the potentials at P & Q respectively what is the potential difference between P and Q

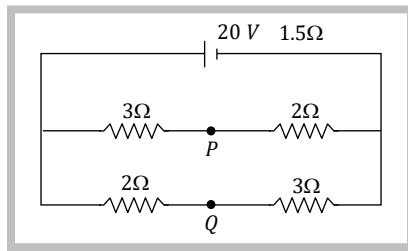

- (a) Zero
- (b) 4 volts ($V_P > V_Q$)
- (c) 4 volt ($V_Q > V_P$)
- (d) 2.5 volt ($V_Q > V_P$)

122. A wire of resistance $10\ \Omega$ is bent to form a circle, P and Q are points on the circumference of the circle dividing it into a quadrant and are connected to a battery of $3\ V$ and internal resistance $1\ \Omega$ as shown in the figure. The currents in the two parts of the circle are

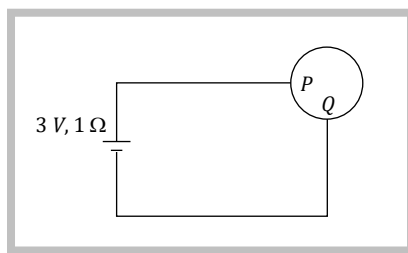

- (a) $\frac{6}{23}\ A$ and $\frac{18}{23}\ A$
- (b) $\frac{5}{26}\ A$ and $\frac{15}{26}\ A$
- (c) $\frac{4}{25}\ A$ and $\frac{12}{25}\ A$
- (d) $\frac{3}{25}\ A$ and $\frac{9}{25}\ A$

123. If the current through $3\ \Omega$ resistor is $0.8\ A$ then the potential drop through $4\ \Omega$ resistor is

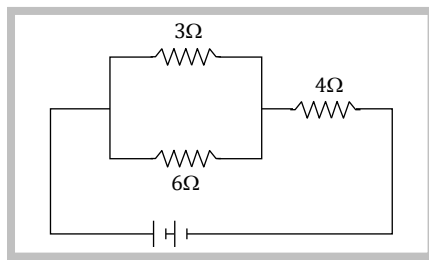

- (a) 9.6 V
- (b) 4.8 V
- (c) 2.6 V
- (d) 2.2 V

124. Potential difference between the points P and Q in the electric circuit shown is

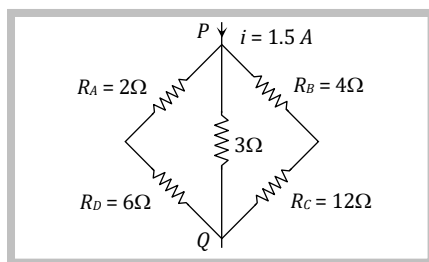

- (a) 4.5 V
- (b) 1.1 V
- (c) 2.4 V
- (d) 2.88 V

125. Five equal resistance each of value R are connected in a form shown alongside. The equivalent resistance of the network

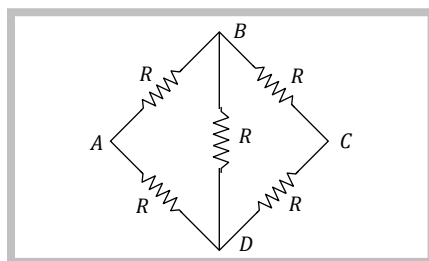

- (a) Between the points B and D is R
- (b) Between the points B and D is $\frac{R}{2}$

(c) Between the points A and C is R

(d) Between the points A and C is $\frac{R}{2}$

126. In the Wheatstone's bridge shown $P = 2 \Omega$, $Q = 3 \Omega$, $R = 6 \Omega$ and $S = 8 \Omega$. In order to obtain balance, shunt resistance across S must be

- (a) 2Ω
- (b) 3Ω
- (c) 6Ω
- (d) 8Ω

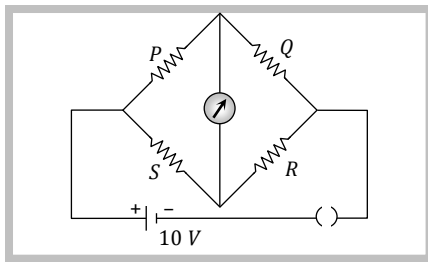

In the circuit shown in the figure, the current through

- (a) The 3Ω resistor is 0.5 A
- (b) The 3Ω resistor is 0.25 A
- (c) The 4Ω resistor is 0.5 A
- (d) The 4Ω resistor is 0.25 A

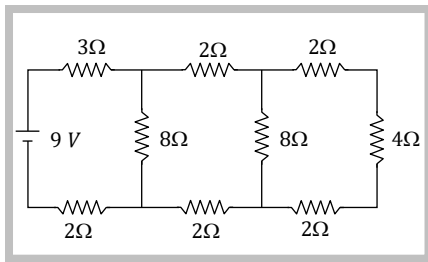

128. Two resistances R_1 and R_2 are made of different materials. The temperature coefficient of the material of R_1 is α and of the materials of R_2 is $-\beta$. The resistance of the series combination of R_1 and R_2 will not change with temperature, if R_1 / R_2 equals

- (a) $\frac{\alpha}{\beta}$
- (b) $\frac{\alpha + \beta}{\alpha - \beta}$
- (c) $\frac{\alpha^2 + \beta^2}{\alpha\beta}$
- (d) $\frac{\beta}{\alpha}$

129. The potential difference across 8 ohm resistance is 48 volt as shown in the figure. The value of potential difference across X and Y points will be

- (a) 160 volt
- (b) 128 volt
- (c) 80 volt
- (d) 62 volt

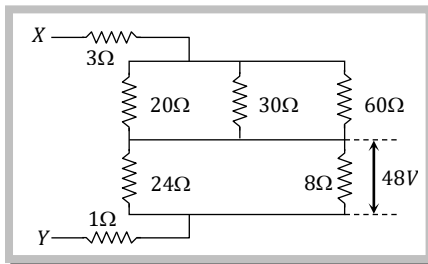

130. In the figure given the value of X resistance will be, when the p.d. between B and D is zero

- (a) 4 ohm
- (b) 6 ohm
- (c) 8 ohm
- (d) 9 ohm

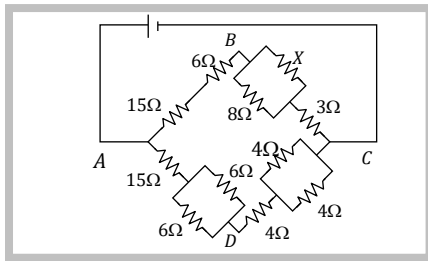

131. In the adjoining circuit, the emf of the cell is 2 volt and the internal resistance is negligible. The resistance of the voltmeter is 80 ohm . The reading of the voltmeter will be

- (a) 0.80 volt
- (b) 1.60 volt
- (c) 1.33 volt
- (d) 2.00 volt

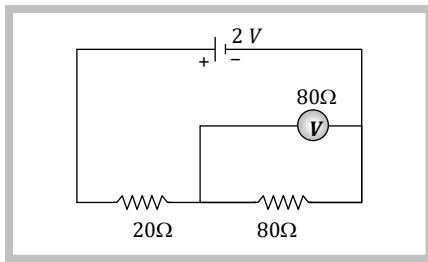

132. In the figure shown, the capacity of the condenser C is $2\mu F$. The current in 2Ω resistor is

- (a) $9 A$
- (b) $0.9 A$
- (c) $\frac{1}{9} A$
- (d) $\frac{1}{0.9} A$

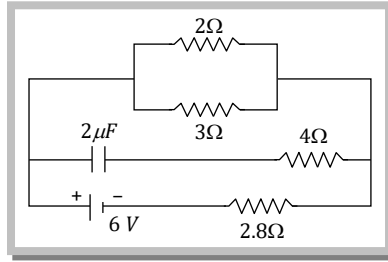

133. In the figure given below find the resistance between points A and B . Both the circle and diameter are made of uniform wire of resistance $1 \times 10^{-4} \text{ ohm-metre}$. The length AB is 2 metre

- (a) $\frac{2}{3} \times 10^{-4} \Omega$
- (b) $\frac{2\pi}{3} \times 10^{-4} \Omega$
- (c) $14.56 \times 10^{-4} \Omega$
- (d) $0.88 \times 10^{-4} \Omega$

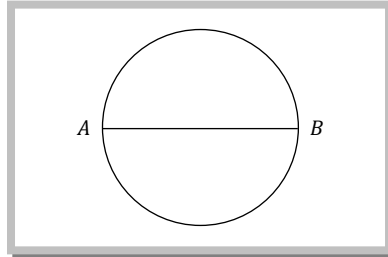

134. You are given several identical resistance each of 10Ω and each capable of carrying maximum current of 1 ampere . It is required to make a suitable combination of these resistances to produce a resistance of 5Ω which can carry a current of 4 ampere . The minimum number of resistance of required of such type is

- (a) 4
- (b) 10
- (c) 8
- (d) 20

135. The value of i in the following circuit diagram will be

- (a) $\frac{3}{2} A$
- (b) $\frac{3}{4} A$
- (c) $\frac{1}{2} A$
- (d) $1 A$

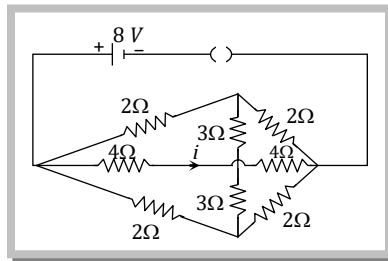

136. In the following circuit the value of currents i_A and i_B are

- (a) $4 A, 3 A$
- (b) $3 A, 4 A$
- (c) $4 A, 4 A$
- (d) $3 A, 3 A$

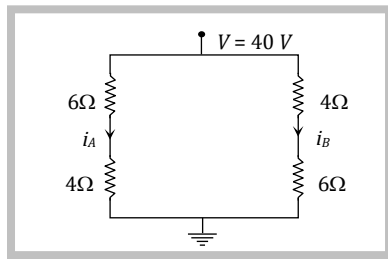

137. The emf of the battery shown in figure is

- (a) $12 V$
- (b) $16 V$
- (c) $18 V$
- (d) $15 V$

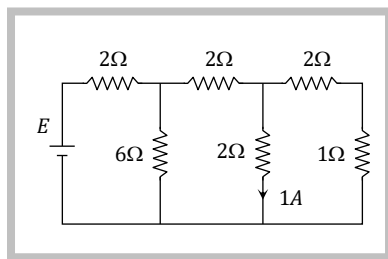

138. When the switch 1 is closed, the current through the $8\ \Omega$ resistance is 0.75 A . When the switch 2 is closed (only), the current through the $2\ \Omega$ resistance is 1 A . The value of E is

- (a) 5 V
 (b) $5\sqrt{2}\text{ V}$
 (c) 10 V
 (d) 15 V

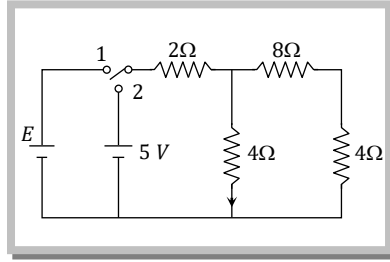

139. An ideal ammeter (zero resistance) is connected as shown. The reading of the ammeter is

- (a) 0
 (b) $\frac{E}{3R}$
 (c) $\frac{E}{5R}$
 (d) $\frac{E}{7R}$

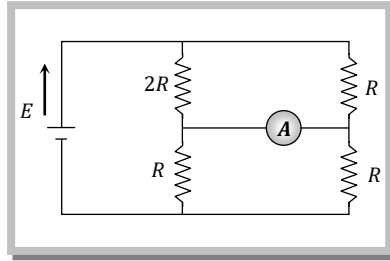

140. In the following circuit, bulb rated as 1.5 V , 0.45 W . If bulb glows with full intensity then what will be the equivalent resistance between X and Y

- (a) $0.45\ \Omega$
 (b) $1\ \Omega$
 (c) $3\ \Omega$
 (d) $5\ \Omega$

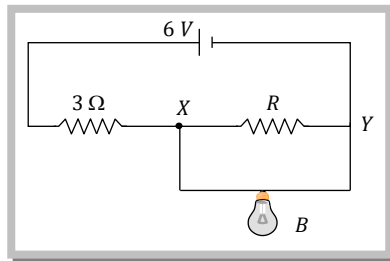

Level-1

141. A 6 volt battery is connected to the terminals of a three metre long wire of uniform thickness and resistance of 100 ohm . The difference of potential between two points on the wire separated by a distance of 50 cm will be

- (a) 1 volt (b) 1.5 volt (c) 2 volt (d) 3 volt

142. n cells each of emf E and internal resistance r send the same current through an external resistance R , whether the cells are connected in series or in parallel. The

- (a) $R = nr$ (b) $R = r$ (c) $r = nR$ (d) $R = n/R$

143. In the circuit, if the forward voltage drop for the diode is 0.5 V , the current will be

- (a) 3.4 mA
 (b) 2 mA
 (c) 2.5 mA

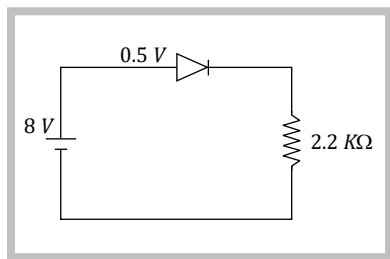

- 155.** The internal resistance of a cell is the resistance of
- (a) Electrodes of the cell (b) Vessel of the cell
(c) Electrolyte used in the cell (d) Material used in the cell
- 156.** Two cells each of emf E and internal resistance r are connected parallel across a resistor R . The power dissipated in the resistor is maximum if
- (a) $R = r$ (b) $R = 2r$ (c) $R = \frac{3r}{2}$ (d) $R = \frac{r}{2}$
- 157.** A current of 2.0 amp passes through a cell of emf 1.5 volts having internal resistance of 0.15 ohm . The potential difference measured in, *volts* across both the ends of cell will be
- (a) 1.35 (b) 1.50 (c) 1.00 (d) 1.20
- 158.** If six identical cells each having an emf of 6 V are connected in parallel, the emf of the combination is
- (a) 1 V (b) 36 V (c) $\frac{1}{6} \text{ V}$ (d) 6 V
- 159.** Two non-ideal batteries are connected in parallel. Consider the following sets :
- (i) The equivalent emf is smaller than either of the emf
(ii) The equivalent internal resistance is smaller than either of the two internal resistance
- (a) Both (i) & (ii) are correct (b) (i) is correct but (ii) is wrong
(c) (ii) is correct but (i) is wrong (d) Both (i) and (ii) are wrong
- 160.** A storage cell is charged by 5 amp d.c. for 18 hours. Its strength after charging will be
- (a) 18 AH (b) 5 AH (c) 90 AH (d) 15 AH
- 161.** In the shown circuit if key K is closed then what is the potential difference across A and B

- (a) 50 V
(b) 45 V
(c) 30 V
(d) 20 V

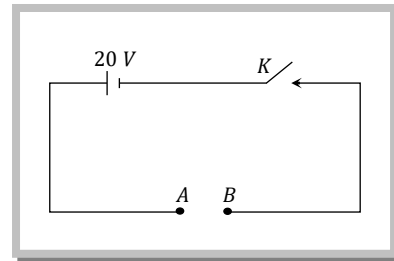

- 162.** Six identical cells of emf E and internal resistance r are connected in parallel, then the net emf and internal resistance of the combination will be
- (a) $6E : 6r$ (b) $E, \frac{r}{6}$ (c) $E, 6r$ (d) $\frac{E}{6}, \frac{r}{6}$
- 163.** When cells are arranged in parallel
- (a) The current capacity decreases (b) The current capacity increases
(c) The emf increases (d) The emf decreases
- 164.** The number of dry cells, each of emf 1.5 volt and internal resistance 0.5 ohm that must be joined in series with a resistance of 20 ohm so as to send a current of 0.6 ampere through the circuit is
- (a) 2 (b) 8 (c) 10 (d) 12
- 165.** The electromotive force of a primary cell is 2 volts . When it is short-circuited it gives a current of 4 amperes . Its internal resistance in *ohms* is
- (a) 0.5 (b) 5.0 (c) 2.0 (d) 8.0
- 166.** Emf of a cell is 1.25 V and its internal resistance is 2Ω . Number of such cells are connected in series with a resistance of 30Ω , so that current in the circuit is 0.5 A is
- (a) 30 (b) 60 (c) 45 (d) 20

- 167.** A torch battery consisting of two cells of 1.45 volts and an internal resistance 0.15Ω , each cell sending currents through the filament of the lamps having resistance 1.5 ohms. The value of current will be
 (a) 16.11 amp (b) 1.611 amp (c) 0.1611 amp (d) 2.6 amp
- 168.** A cell of emf 1.5 V having a finite internal resistance is connected to a load resistance of 2Ω . For maximum power transfer the internal resistance of the cell should be
 (a) 4 ohm (b) 0.5 ohm (c) 2 ohm (d) None of these
- 169.** Two cells of equal emf and of internal resistances r_1 and r_2 ($r_1 > r_2$) are connected in series. On connecting this combination to an external resistance R , it is observed that the p.d. across the first cell becomes zero. The value of R will be
 (a) $r_1 + r_2$ (b) $r_1 - r_2$ (c) $\frac{r_1 + r_2}{2}$ (d) $\frac{r_1 - r_2}{2}$
- 170.** It is easier to start a car engine on a hot day than a cold day. This is because internal resistance of the car battery
 (a) Decreases with rise in temperature (b) Increases with rise in temperature
 (c) Decreases with fall in temperature (d) Non of the above
- 171.** 36 identical cell each having emf 1.5 volt and internal resistance 0.5Ω are connected in series with an external resistance of 12Ω . If 8 cells are wrongly connected then current through the circuit will be
 (a) 0.5 A (b) 1 A (c) 2 A (d) 4 A

Level-2

- 172.** Eels are able to generate current with biological cells called electroplaques. The electroplaques in an eel are arranged in 100 rows, each row stretching horizontally along the body of the fish containing 5000 electroplaques. The arrangement is suggestively shown below. Each electroplaques has an emf of 0.15 V and internal resistance of 0.25Ω

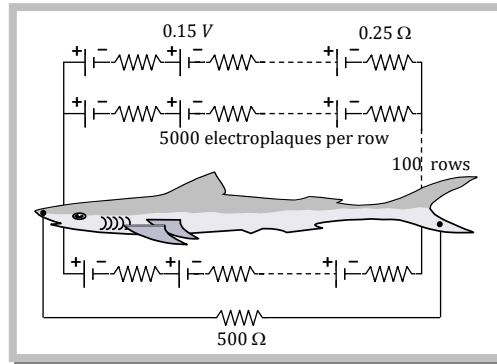

The water surrounding the eel completes a circuit between the head and its tail. If the water surrounding it has a resistance of 500Ω , the current an eel can produce in water is about.

- (a) 1.5 A (b) 3.0 A (c) 15 A (d) 30 A
- 173.** A battery is charged at a potential of 15 V for 8 hours when the current flowing is 10 A. the battery on discharge supplies a current of 5 A for 15 hours. The mean terminal voltage during discharge is 14 V. The "Watt-hour" efficiency of the battery is
 (a) 90% (b) 87.5% (c) 82.5% (d) 80%
- 174.** Consider four circuits shown in the figure below. In which circuit power dissipated s greatest ? (Neglect the internal resistance of the power supply)

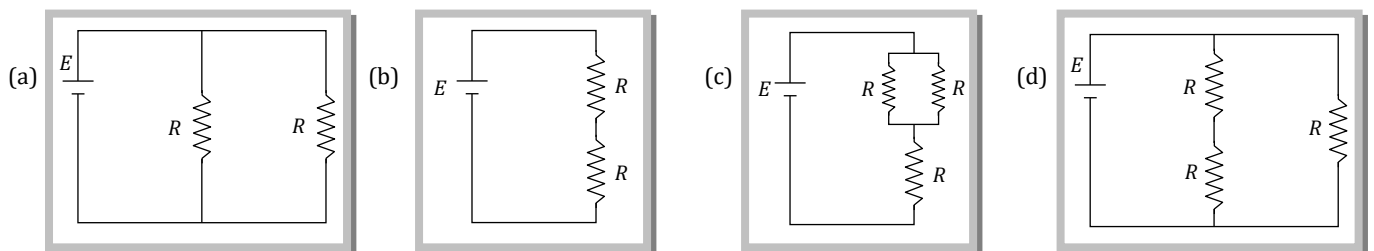

- 175.** In the steady state what will be the power dissipation in following circuit

- (a) 1.5 W

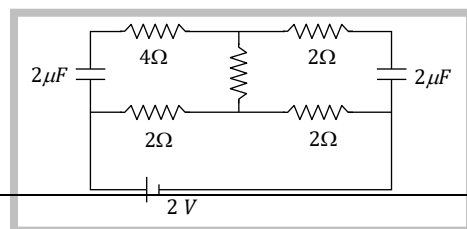

- (b) 2 W
- (c) 1 W
- (d) None of these

In the figure shows, the potential difference across AB is 8.5 V . If the internal resistance of the battery is $1\ \Omega$, it's emf is

- (a) 18 V
- (b) 15 V
- (c) 9 V
- (d) 6 V

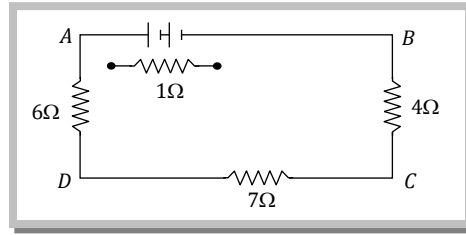

177. Two batteries of emf 4 V and 8 V with internal resistance of $1\ \Omega$ and $2\ \Omega$ are connected in a circuit with resistance of $9\ \Omega$. The current and potential difference between the points A, B are

- (a) $\frac{1}{3}\text{ A}$ and 3 V
- (b) $\frac{1}{6}\text{ A}$ and 4 V
- (c) $\frac{1}{9}\text{ A}$ and 9 V
- (d) $\frac{1}{12}\text{ A}$ and 12 V

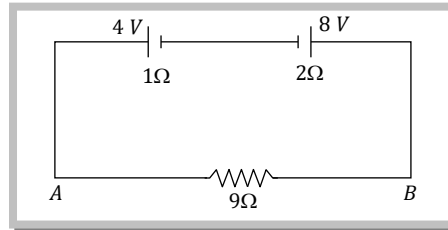

178. When connected across the terminals of a cell, a voltmeter measures 5 V and a connected ammeter measures 10 A of current. A resistance of 2 ohms is connected across the terminals of the cell. The current flowing through this resistance will be

- (a) 2.5 A
- (b) 2.0 A
- (c) 5.0 A
- (d) 7.5 A

179. Two resistances R_1 and R_2 are joined as shown in the figure to two batteries of emf E_1 and E_2 . If E_2 is short-circuited, the current through R_1 is

- (a) E_1/R_1
- (b) E_2/R_1
- (c) E_2/R_2
- (d) $E_1/(R_2 + R_1)$

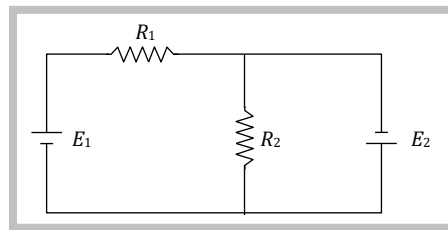

180. A battery is first connected in parallel to resistor R_1 and then R_2 . The value of R_0 of internal resistance of battery for which heat released in external circuit be same in both cases is

- (a) $\frac{R_1 R_2}{R_1 + R_2}$
- (b) $\sqrt{R_1 R_2}$
- (c) $R_1 R_2$
- (d) $\frac{R_1 R_2}{2}$

181. If $V_{AB} = 4\text{ V}$ in the given figure, then resistance X will be

- (a) $5\ \Omega$
- (b) $10\ \Omega$
- (c) $15\ \Omega$
- (d) $20\ \Omega$

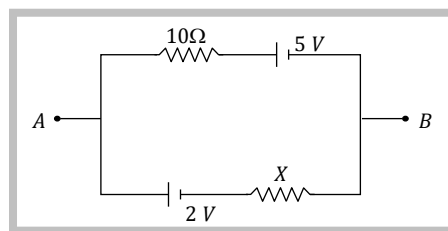

182. Two identical cells of emf 1.5 V an internal resistance $1\ \Omega$ are in series. A third cell of similar parameters is connected in parallel to the combination. The terminal voltages of cells A, B and C are

- (a) $1, 1, 2\text{ V}$

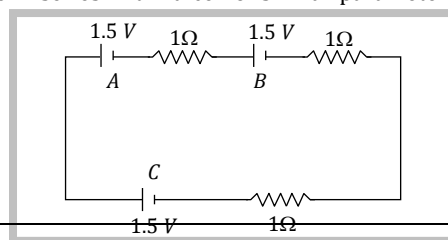

- (b) 1.5, 1.5, 1.5 V
- (c) 1.5, 0, 0 V
- (d) 2, 1, 1 V

183. The resistor in which maximum heat will be produced is

- (a) 6 Ω
- (b) 2 Ω
- (c) 5 Ω
- (d) 4 Ω

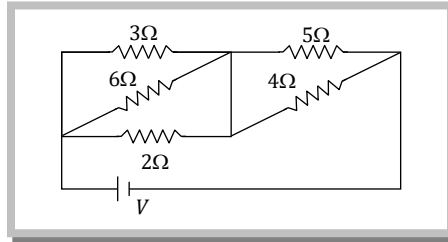

184. In the circuit shown the total power developed in the 4 Ω and 8 Ω resistors is 18 W. The power in watts developed in the 6 Ω resistor is

- (a) 6
- (b) 12
- (c) 8
- (d) 18

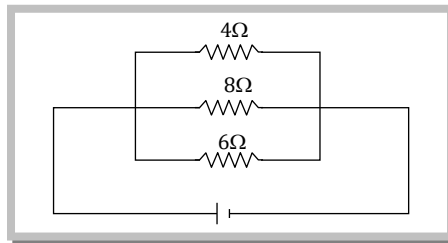

185. A battery consists of a variable number 'n' of identical cells having internal resistances connected in series. The terminals of battery are short circuited and the current i is measured. Which of the graph below shows the relationship between i and n

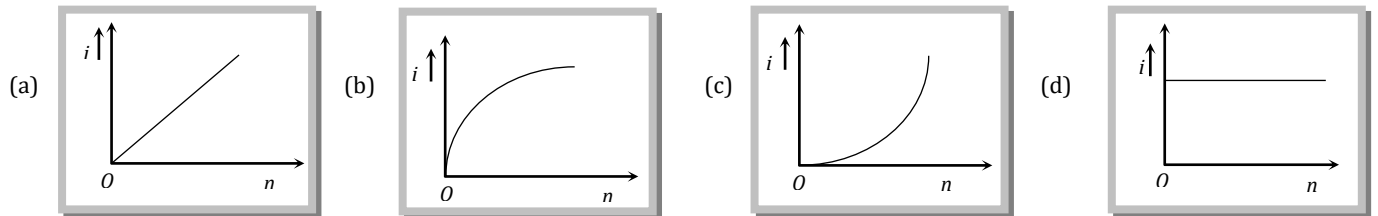

186. n identical cells, each of emf E and internal resistance r, are joined in series to form a closed circuit. One cell (A) is joined with reversed polarity. The potential difference across each cell, except A is

- (a) $\frac{2E}{n}$
- (b) $\frac{n-1}{n} E$
- (c) $\frac{n-2}{n} E$
- (d) $\frac{2n}{n-2} E$

187. N identical cell are connected to form a battery. When the terminals of the battery are joined directly (short-circuited), current i flows in the circuit. To obtain the maximum value of i

- (a) All the cells should be joined in series
- (b) All the cells should be joined in parallel
- (c) Two rows of $\frac{N}{2}$ cells each should be joined in parallel
- (d) \sqrt{N} rows of \sqrt{N} cells each should be joined in parallel, given that \sqrt{N} is an integer

188. In the given circuit current through the cell is

- (a) 1/3 A
- (b) 2/3 A
- (c) 4/3 A
- (d) 5/3 A

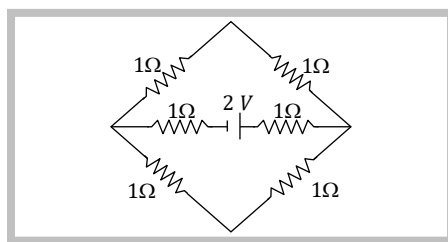

189. Kirchoff's first and second laws in the electricity are the laws respectively of

- (a) Energy and Momentum conservation
 (b) Momentum and charge conservation
 (c) Mass and charge conservation
 (d) Charge and energy conservation

190. The value of current i , in a section of complicated network is

- (a) 1.3 A
 (b) 2 A
 (c) 1 A
 (d) 1.7 A

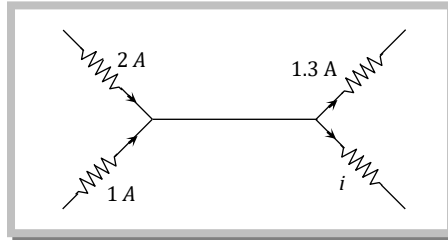

191. In the circuit shown in figure

- (a) Current passing through $2\ \Omega$ resistance is zero
 (b) Current passing through $4\ \Omega$ resistance is 5 A
 (c) Current passing through $5\ \Omega$ resistance is 4 A
 (d) All of the above

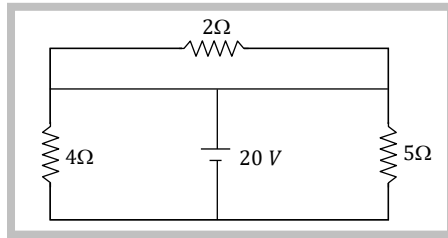

192. Four identical batteries, each of emf E and internal resistance r are connected in series to form a closed loop, as shown in figure. Current through each battery and potential difference across each battery are respectively

- (a) $\frac{4E}{r}$ Amp and 0 volt
 (b) 0 Amp and E volt
 (c) $\frac{2E}{r}$ Amp and 0 volt
 (d) $\frac{E}{r}$ Amp and 0 volt

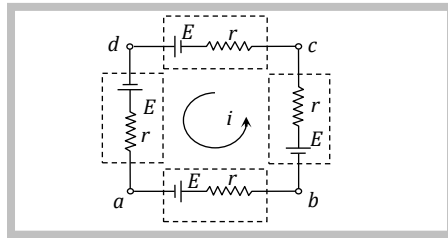

193. In the following circuit in steady state. Potential difference across capacitor will be

- (a) 2.5 V
 (b) 1.5 V
 (c) 1 V
 (d) 0 V

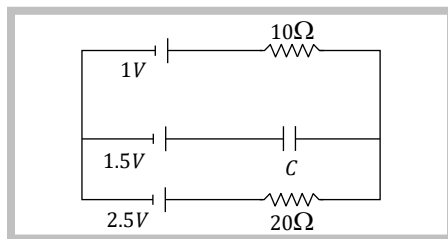

Level-2

194. In the following circuit current i_1 is

- (a) 0.4 A
 (b) -0.4 A
 (c) 0.8 A
 (d) -0.8 A

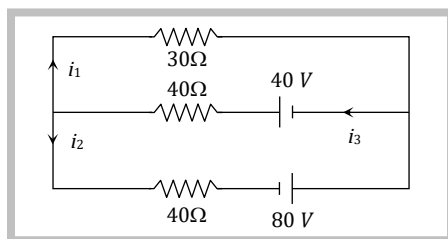

195. The reading of ammeter in the adjoining diagram will

- (a) $\frac{2}{17}$ A

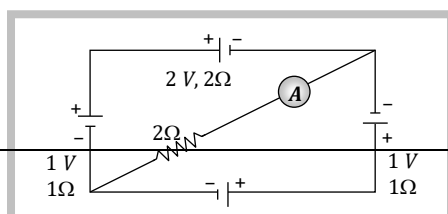

(b) $\frac{3}{11} A$

(c) $\frac{1}{13} A$

(d) $\frac{4}{15} A$

196. In the circuit shown in figure potential difference between points A and B is 16V. The current passing through 2Ω resistance will be

(a) 2.5 A

(b) 3.5 A

(c) 4.0 A

(d) Zero

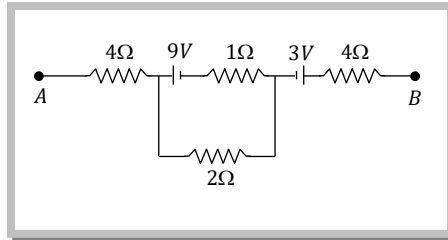

197. Current through wire XY of circuit shown is

(a) 1A

(b) 4A

(c) 2A

(d) 3A

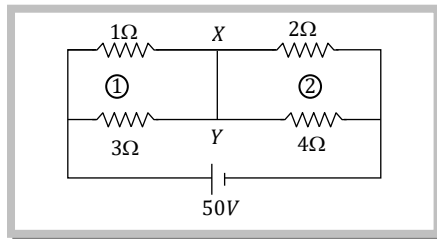

198. In the following part of a circuit, what will be the potential difference between A and B i.e. ($V_B - V_A$)

(a) 3 V

(b) 15 V

(c) - 5.1 V

(d) + 5.1 V

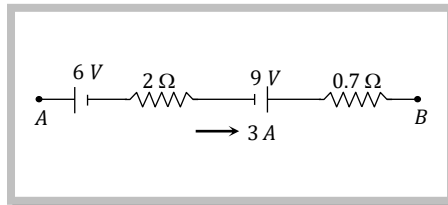

Level-1

199. In a metre bridge experiment null point is obtained at 20 cm. from one end of the wire when resistance X is balanced against another resistance Y. If $X < Y$, then where will be the new position of the null point from the same end, if one decides to balance a resistance of 4 X against Y

(a) 40 cm

(b) 80 cm

(c) 50 cm

(d) 70 cm

200. An unknown resistance R_1 is connected in series with a resistance of 10Ω. This combination is connected to one gap of a metre bridge while a resistance R_2 is connected in the other gap. The balance point is at 50 cm. Now, when the 10 Ω resistance is removed the balance position shifts to 40 cm. The value of R_1 is (in ohm)

(a) 10

(b) 20

(c) 40

(d) 60

201. A galvanometer acting as a voltmeter will have

(a) A low resistance in parallel with its coil

(b) A low resistance in series with its coil

(c) A high resistance in parallel with its coil

(d) A high resistance in series with its coil

202. The maximum current that can be measured by a galvanometer of resistance 40Ω is 10 mA. It is converted into a voltmeter that can read upto 50 V. The resistance to be connected in series with the galvanometer is (in ohm)

(a) 4050

(b) 2010

(c) 4960

(d) 5040

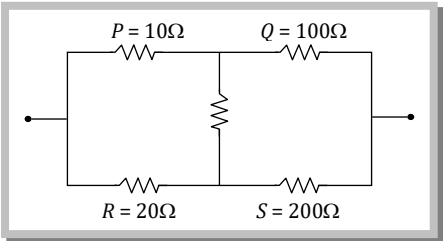
- 203.** An ammeter reads upto 1 ampere. Its internal resistance is 0.81 ohm. To increase the range to 10 A the value of the required shunt is
- (a) 0.09 Ω (b) 0.03 Ω (c) 0.3 Ω (d) 0.9 Ω
- 204.** The length of a wire of a potentiometer is 100 cm, and the e.m.f. of its standard cell is E volt. It is employed to measure the e.m.f. of a battery whose internal resistance is 0.5 Ω . If the balance point is obtained at $l = 30$ cm from the positive end, the e.m.f. of the battery is
- (a) $\frac{30E}{100}$ (b) $\frac{30E}{100.5}$
- (c) $\frac{30E}{(100 - 0.5)}$ (d) $\frac{30(E - 0.5i)}{100}$, where i is the current in the potentiometer wire
- 205.** A cell of internal resistance 3 ohm and emf 1 volt is connected to a uniform wire of length 500 cm and resistance 3 ohm. The potential gradient in the wire is
- (a) 30 mV/cm (b) 1 mV/cm (c) 20 mV/cm (d) 4 mV/cm
- 206.** In a meter bridge with standard resistance of 5 Ω in the left gap the ratio of balancing lengths of meter bridge wire is 2 : 3. The unknown resistance is
- (a) 1 Ω (b) 15 Ω (c) 7.5 Ω (d) 3.3 Ω
- 207.** An ammeter of 100 Ω resistance gives full deflection for the current of 10^{-5} amp. Now the shunt resistance required to convert it into ammeter of 1 amp. range, will be
- (a) 10^{-4} Ω (b) 10^{-5} Ω (c) 10^{-3} Ω (d) 10^{-1} Ω
- 208.** A potentiometer has uniform potential gradient. The specific resistance of the material of the potentiometer wire is 10^{-7} ohm-meter and the current passing through it is 0.1 ampere; cross-section of the wire is 10^{-6} m². The potential gradient along the potentiometer wire is
- (a) 10^{-4} V/m (b) 10^{-6} V/m (c) 10^{-2} V/m (d) 10^{-8} V/m
- To send 10% of the main current through a moving coil galvanometer of resistance 99 ohm, the shunt required is
- (a) 99 ohm (b) 10 ohm (c) 11 ohm (d) 9 ohm
- 210.** When a 12 Ω resistor is connected with a moving coil galvanometer then its deflection reduces from 50 divisions to 10 divisions. The resistance of the galvanometer is
- (a) 24 Ω (b) 36 Ω (c) 48 Ω (d) 60 Ω
- 211.** The balanced wheatstone bridge is shown in figure. If P is made 11 Ω then which of the following condition will not balance the wheatstone bridge again
- (a) R increases by 2 Ω
- (b) Q increases by 10 Ω
- (c) S increases by 20 Ω
- (d) None of these
- 
- 212.** An ammeter and a voltmeter of resistance R are connected in series to an electric cell of negligible internal resistance. Their readings are A and V respectively. If another resistance R is connected in parallel with the voltmeter
- (a) Both A and V will increase (b) Both A and V will decrease
- (c) A will decrease and V will increase (d) A will increase and V will decrease
- 213.** 100 mA current gives a full scale deflection in a galvanometer of 2 Ω resistance. The resistance connected with the galvanometer to convert it into a voltmeter to measure 5V is
- (a) 98 Ω (b) 52 Ω (c) 50 Ω (d) 48 Ω
- 214.** A galvanometer of resistance 20 Ω is to be converted into an ammeter of range 1 A. If a current of 1 mA produces full scale deflection, the shunt required for the purpose is

- (a) 0.01Ω (b) 0.05Ω (c) 0.02Ω (d) 0.04Ω

215. A 100 ohm galvanometer gives full scale deflection at 10 mA . How much shunt is required to read 100 mA

- (a) 11.11 ohm (b) 9.9 ohm (c) 1.1 ohm (d) 4.4 ohm

216. To convert a 800 mV range millivolt meter of resistance 40Ω into a galvanometer of 100 mA range, the resistance to be connected as shunt is

- (a) 10Ω (b) 20Ω (c) 30Ω (d) 40Ω

217. A milliammeter having resistance of 2000Ω shows maximum deflection for a current of $200 \mu\text{A}$. If it is to be converted into a voltmeter with maximum deflection of 2 V , the circuit to be drawn is

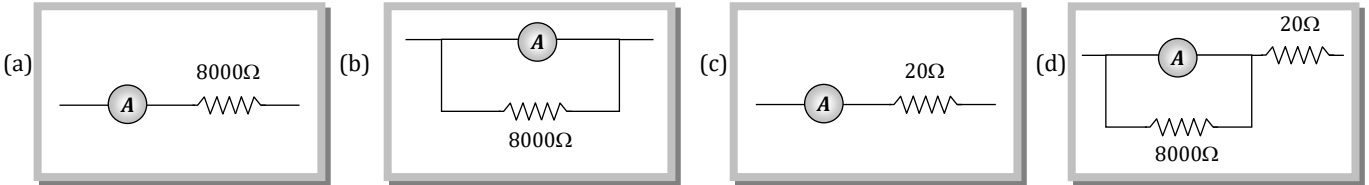

218. In a circuit 5 percent of total current passes through a galvanometer. If resistance of the galvanometer is G then value of the shunt is

- (a) $19 G$ (b) $20 G$ (c) $\frac{G}{20}$ (d) $\frac{G}{19}$

219. A voltmeter having resistance of $50 \times 10^3 \text{ ohm}$ is used to measure the voltage in a circuit. To increase the range of measurement 3 times the additional series resistance required is

- (a) 10^5 ohm (b) 150 kilo ohm (c) 900 kilo ohm (d) $9 \times 10^6 \text{ ohm}$

220. An ammeter gives full deflection when a current of 2 amp. flows through it. The resistance of ammeter is 12 ohms . If the same ammeter is to be used for measuring a maximum current of 5 amp. , then the ammeter must be connected with a resistance of

- (a) 8 ohms in series (b) 18 ohms in series (c) 8 ohms in parallel (d) 18 ohms in parallel

221. AB is a potentiometer wire of length 100 cm and its resistance is 10 ohms . It is connected in series with a resistance $R = 40 \text{ ohms}$ and a battery of emf 2 V and negligible internal resistance. If a source of unknown emf E is balanced by 40 cm length of the potentiometer wire, the value of E is

- (a) 0.8 V
 (b) 1.6 V
 (c) 0.08 V
 (d) 0.16 V

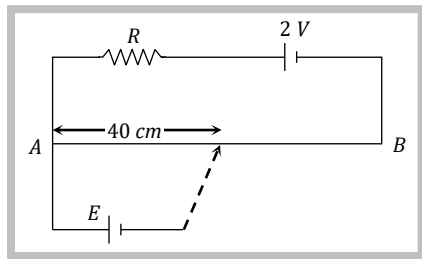

222. The resistance of an ideal ammeter is

- (a) Infinite (b) Very high (c) Small (d) Zero

223. In the figure battery E is balanced on 55 cm length of potentiometer wire, but when a resistance of 10Ω is connected in parallel with the battery then it balances on 50 cm of length of potentiometer wire. The internal resistance of the battery (r) is

- (a) 1Ω
 (b) 3Ω
 (c) 10Ω
 (d) 5Ω

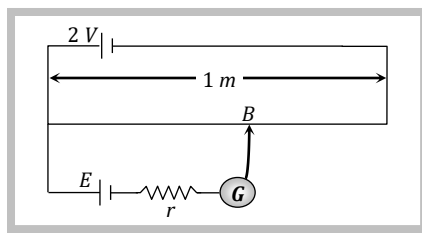

224. In order to convert a milliammeter of range 1.0 mA and resistance 1.0 ohm into a voltmeter of range 10 V , a resistance of how many ohms should be connected with it and in what manner

- (a) 999 ohms in series (b) 999 ohms in parallel (c) $9,999 \text{ ohms}$ in series (d) $9,999 \text{ ohms}$ in parallel

225. If an ammeter is connected in parallel to a circuit, it is likely to be damaged due to excess

237. In an experiment of Wheatstone bridge, a null point is obtained at the centre of the bridge wire. When a resistance of $10\ \Omega$ is connected in one gap, the value of resistance in other gap is
- (a) $10\ \Omega$ (b) $5\ \Omega$ (c) $1/5\ \Omega$ (d) $500\ \Omega$
238. A potentiometer is used for the comparison of emf of two cells E_1 and E_2 . For cell E_1 the no deflection point is obtained at $20\ \text{cm}$ and for E_2 the no deflection point is obtained at $30\ \text{cm}$. The ratio of their emf's will be
- (a) $2/3$ (b) $1/2$ (c) 1 (d) 2
239. The length of a potentiometer wire is $10\ \text{m}$. The distance between the null points on its wire corresponding to two cell comes out to be $60\ \text{cm}$. If the difference of emf's of the cells is $0.4\ \text{volt}$ then the potential gradient on potentiometer will be
- (a) $0.67\ \text{V/m}$ (b) $0.5\ \text{V/m}$ (c) $2.5\ \text{V/m}$ (d) $0\ \text{V/m}$
240. If the radius of a potentiometer wire is increased 4 time, keeping its length constant then the value of potential gradient will become
- (a) Four times (b) Two times (c) Half (d) Constant

241. The adjoining diagram shows a potentiometer circuit to determine an unknown emf E . When the jockey makes contact at point A , the deflection is towards left. On moving the jockey from A to B , the deflection always remains left but goes on decreasing. This means that

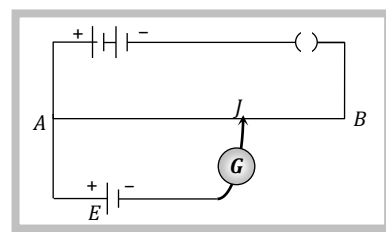

- (a) The unknown emf E is wrongly connected
 (b) The main potentiometer battery is wrongly
 (c) The unknown emf is less than the battery emf
 (d) The unknown emf is greater than the battery emf

242. In using a Wheatstone bridge to determine an unknown resistance the battery key is always pressed first and galvanometer key is pressed thereafter. If the order of pressing of the keys is reversed, it can cause
- (a) A damage to the battery (b) A damage to the unknown resistance
 (c) A damage to the galvanometer (d) A decrease in the sensitivity of the bridge

243. A potentiometer is to be calibrated with a standard cell using the circuit shown in the diagram. The balance point is found to be near L . To improve accuracy the balance point should be nearer M . This may be achieved by

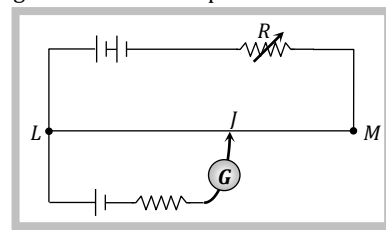

- (a) Replacing the galvanometer with one of lower resistance
 (b) Replacing the potentiometer wire one of higher resistance per unit length
 (c) Putting a shunt resistance in parallel with the galvanometer
 (d) Increasing the resistance R

Level-2

244. A galvanometer of $50\ \text{ohm}$ resistance has 25 divisions. A current of 4×10^{-4} ampere gives a deflection of one division. To convert this galvanometer into a voltmeter having a range of 25 volts, it should be connected with a resistance of
- (a) $2550\ \Omega$ in series (b) $2450\ \Omega$ in series (c) $2500\ \Omega$ as a shunt (d) $245\ \Omega$ as a shunt
245. A galvanometer of resistance $36\ \Omega$ is changed into an ammeter by using a shunt of $4\ \Omega$. The fraction i_0 of total current passing through the galvanometer is
- (a) $\frac{1}{40}$ (b) $\frac{1}{4}$ (c) $\frac{1}{140}$ (d) $\frac{1}{10}$
246. Two resistances of $400\ \Omega$ and $800\ \Omega$ are connected in series with $6\ \text{volt}$ battery of negligible internal resistance. A voltmeter of resistance $10,000\ \Omega$ is used to measure the potential difference across $400\ \Omega$. The error in the measurement of potential difference in volts approximately is
- (a) 0.01 (b) 0.02 (c) 0.03 (d) 0.05

247. In the shown arrangement of the experiment of the meter bridge if AC corresponding to null deflection of galvanometer is x , what would be its value if the radius of the wire AB is doubled

- (a) x
- (b) $x/4$
- (c) $4x$
- (d) $2x$

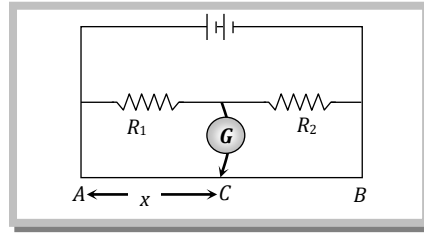

248. In the circuit shown here, the readings of the ammeter and voltmeter are

- (a) $6\text{ A}, 60\text{ V}$
- (b) $0.6\text{ A}, 6\text{ V}$
- (c) $6\text{ A}, 6\text{ V}$
- (d) $6/11\text{ A}, 60/11\text{ V}$

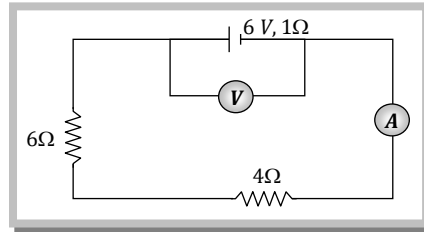

249. A voltmeter has range $0 - V_1$, volt with a series resistance R . When the series resistance is increased to $2R$, the range becomes $0 - V_2$ volt. The correct relation between V_1 and V_2 is

- (a) $V_2 = 2V_1$
- (b) $V_2 > 2V_1$
- (c) $V_2 < 2V_1$
- (d) $V_2 = \frac{3}{2} V_1$ exactly

250. A microammeter has a resistance of $100\ \Omega$ and full scale range of $50\ \mu\text{A}$. It can be used as a voltmeter or as a higher range ammeter provided a resistance is added to it. Pick the correct range and resistance combination

- (a) 50 V range with $10\text{ k}\Omega$ resistance in series
- (b) 10 V range with $200\text{ k}\Omega$ resistance in series
- (c) 10 mA range with $1\text{ k}\Omega$ resistance in parallel
- (d) 10 mA range with $0.1\text{ k}\Omega$ resistance in parallel

251. In the circuit shown $P \neq R$, the reading of galvanometer is same with switch S is open or closed. Then

- (a) $i_R = i_G$
- (b) $i_P = i_G$
- (c) $i_Q = i_G$
- (d) $i_Q = i_R$

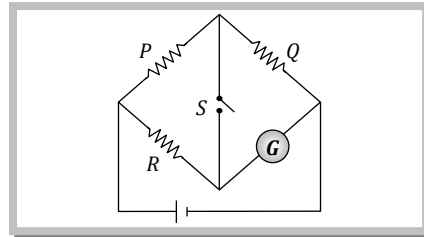

252. In the diagram shown, the reading of voltmeter is 20 V and that of ammeter is 4 A . The value of R should be

- (a) Equal to $5\ \Omega$
- (b) Greater from $5\ \Omega$
- (c) Less than $5\ \Omega$
- (d) Greater or less than $5\ \Omega$ depends on the material of R

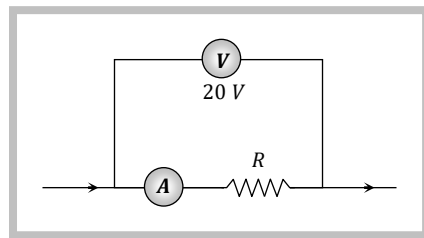

253. A battery of emf E is connected in series with three resistances R , $2R$ and $3R$. The voltage across $2R$ is measured with a voltmeter whose resistance is $10R$, what is the percentage error

- (a) $+11.76\%$
- (b) -11.76%
- (c) $+5.88\%$
- (d) -5.88%

254. A potential difference of 220 V is maintained across a 12000 ohms rheostat AB as shown in figure. The voltmeter V has a resistance of 6000 ohms and point C is at one fourth of the distance from A to B . What is the reading in the voltmeter

- (a) 20 V

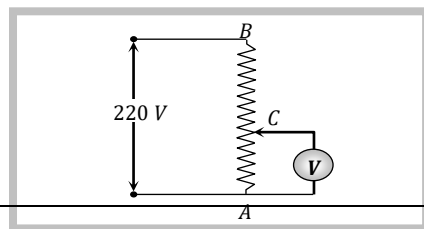

- (b) 40 V
- (c) 60 V
- (d) 0 V

255. A , B and C are voltmeter of resistances R , $1.5 R$ and $3 R$ respectively. When some potential difference is applied between X and Y , the voltmeter readings are V_A , V_B and V_C respectively

- (a) $V_A = V_B = V_C$
- (b) $V_A \neq V_B = V_C$
- (c) $V_A = V_B \neq V_C$
- (d) $V_B \neq V_A = V_C$

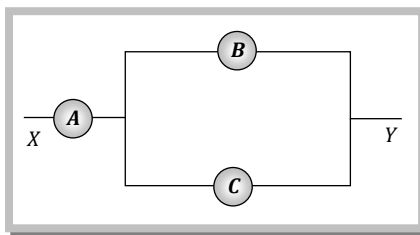

256. In the following circuit diagram (figure), $E = 4V$, $r = 1 \Omega$ and $R = 45 \Omega$, then reading of the ammeter A will be

- (a) 1 A
- (b) $\frac{1}{2}$ A
- (c) $\frac{1}{8}$ A
- (d) $\frac{1}{4}$ A

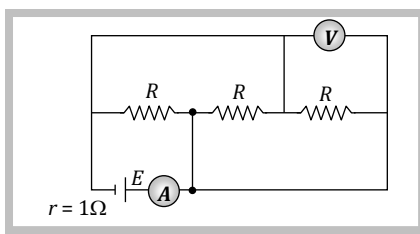

257. Consider the circuits shown in the figure. Both the circuits are taking same current from battery but current through R in the second circuit is $\frac{1}{10}$ th of current through R in the first circuit. If R is 11Ω , the value of R_1 and R_2

- (a) 9.9Ω
- (b) 11Ω
- (c) 8.8Ω
- (d) 7.7Ω

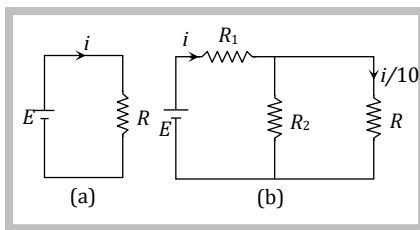

258. In the circuit shown in figure when switch S_1 is closed and S_2 is open, the ideal voltmeter shows a reading 18 V. When switch S_2 is closed and S_1 is open, the reading of the voltmeter is 24 V. When S_1 and S_2 both are closed the voltmeter reading will be

- (a) 14.4 V
- (b) 20.6 V
- (c) 24.2 V
- (d) 10.8 V

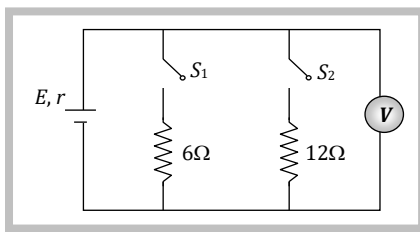

259. A galvanometer of resistance 20Ω gives a full scale deflection when a current of $0.04 A$ is passed through it. It is desired to convert it into an ammeter reading $20 A$ in full scale. The only shunt available is 0.05Ω resistance. The resistance that must be connected in series with the coil of the galvanometer is

- (a) 4.95Ω
- (b) 5.94Ω
- (c) 9.45Ω
- (d) 12.62Ω

260. The length of a potentiometer wire is l . A cell of emf E is balanced at a length $\frac{l}{3}$ from the positive end of the wire. If the length of the wire is increased by $\frac{l}{2}$. At what distance will the same coil give a balance point

- (a) $\frac{2l}{3}$
- (b) $\frac{l}{2}$
- (c) $\frac{l}{6}$
- (d) $\frac{4l}{3}$

261. A milliammeter of range $10 mA$ and resistance 9Ω is joined in a circuit as shown. The ammeter gives full scale deflection for current i when A and B are used as its terminals, i.e., current enters at A and leaves at B (C is left isolated). The value of i is

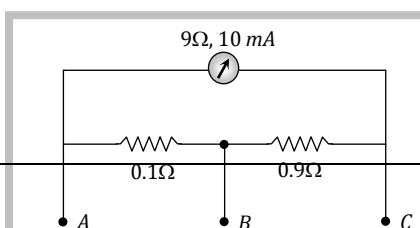

- (a) 100 mA
- (b) 900 mA
- (c) 1 A
- (d) 1.1 A

262. A battery of emf E volt is connected to a resistance network as shown in the figure. If the deflections in the galvanometers G_1 and G_2 are zero, then the ratio of emfs of cell E_1 and E_2 is

- (a) $1 : 1$
- $3 : 2$
- $2 : 1$
- $1 : 2$

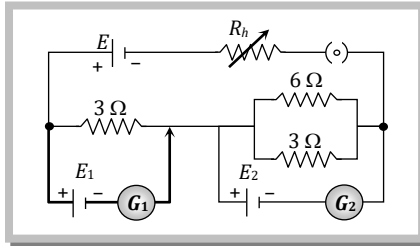

263. In the given circuit ammeter and voltmeter are ideal and battery of 6 V has internal resistance $1\ \Omega$. The reading of voltmeter and ammeter is

- (a) Zero, $\frac{4}{3}\ \Omega$
- (b) $\frac{4}{3}\text{ V}$, zero
- (c) 6 A , 0.1 A
- (d) 3.6 V , 0.6 A

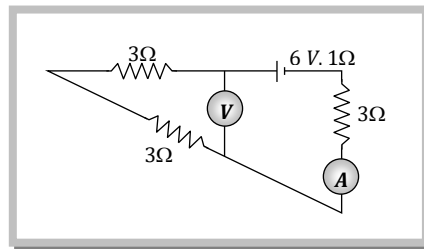

Level-1

1.

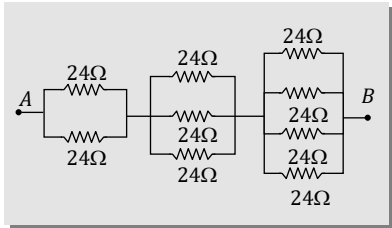

- (a) 21.6Ω
- (b) $\frac{24}{3} \Omega$
- (c) 26Ω
- (d) 36Ω

2.

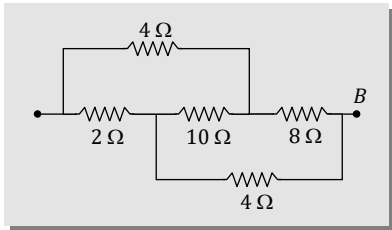

- (a) 2Ω
- (b) 4Ω
- (c) 8Ω
- (d) 16Ω

3.

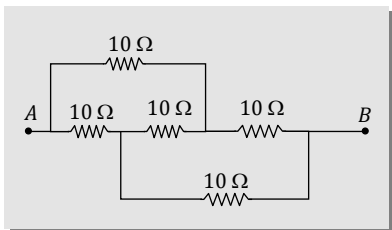

- (a) 10Ω
- (b) 40Ω
- (c) 20Ω
- (d) $\frac{5}{2} \Omega$

4.

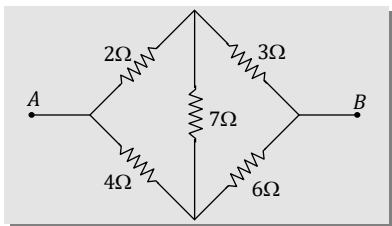

- (a) $\frac{10}{3} \Omega$
- (b) $\frac{20}{3} \Omega$
- (c) 15Ω
- (d) 6Ω

5.

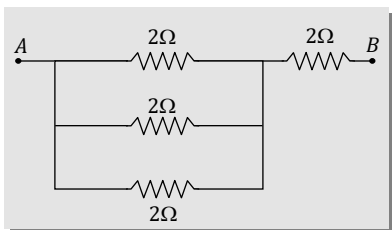

- (a) 2 ohm
- (b) 4 ohm
- (c) $1 \frac{2}{3} \text{ ohm}$
- (d) $2 \frac{2}{3} \text{ ohm}$

6.

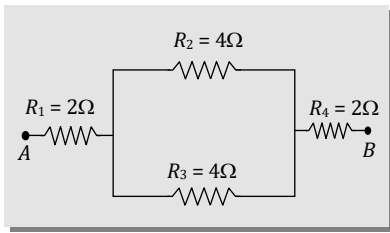

- (a) 8Ω
- (b) 6Ω
- (c) 4Ω
- (d) 2Ω

7.

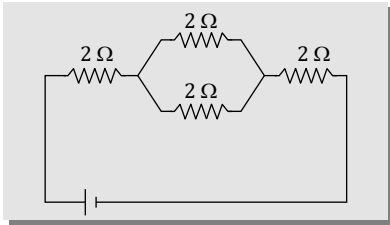

- (a) 8Ω
- (b) 6Ω
- (c) 5Ω
- (d) 4Ω

8.

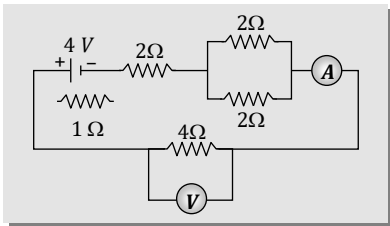

- (a) 6Ω
- (b) 7Ω
- (c) 8Ω
- (d) 9Ω

9.

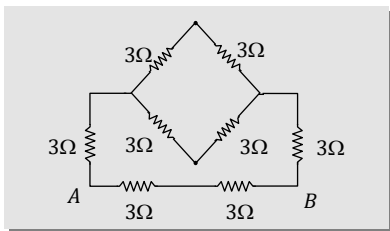

- (a) 2 ohm
- (b) 18 ohm
- (c) 6 ohm
- (d) 3.6 ohm

10.

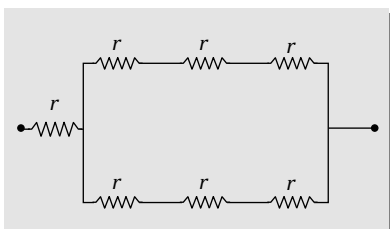

- (a) $2r$
- (b) $4r$
- (c) $10r$
- (d) $5r/2$

11.

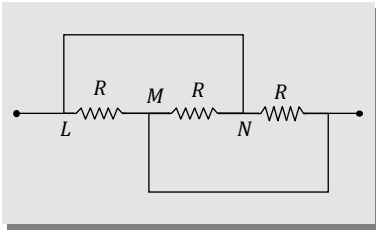

- (a) R
- (b) $2R$
- (c) $\frac{R}{2}$
- (d) $\frac{R}{3}$

12.

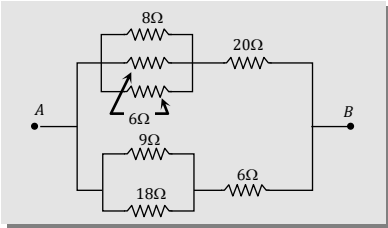

- (a) 6 ohm
- (b) 8 ohm
- (c) 16 ohm
- (d) 24 ohm

13.

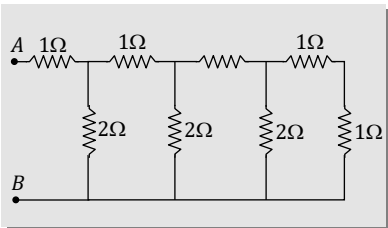

- (a) 4 Ω
- (b) 8 Ω
- (c) 6 Ω
- (d) 2 Ω

14.

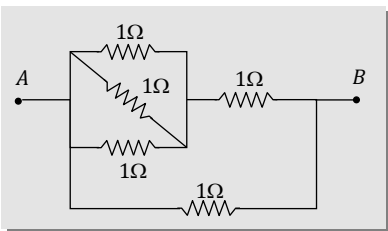

- (a) 0.25 Ω
- (b) $\frac{4}{7}$ Ω
- (c) $\frac{7}{4}$ Ω
- (d) 1 Ω

15.

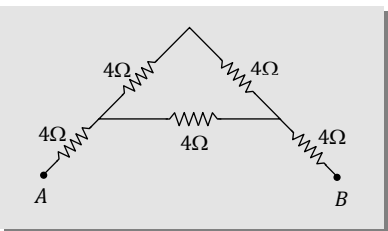

- (a) 10.6 Ω
- (b) 20 Ω
- (c) 16 Ω
- (d) 8 Ω

16.

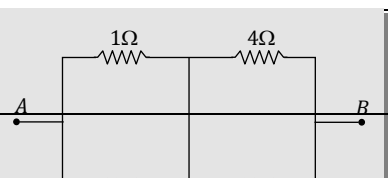

- (a) $1\ \Omega$
- (b) $9\ \Omega$
- (c) $2\ \Omega$
- (d) $6\ \Omega$

17.

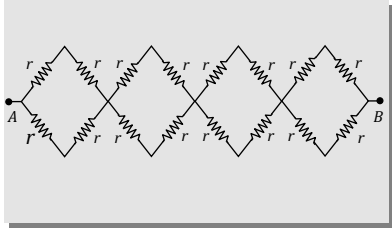

- (a) r
- (b) $2r$
- (c) $\frac{4}{3}r$
- (d) $4r$

Level-2

18.

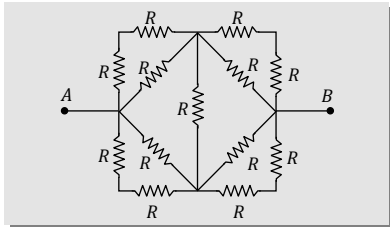

- (a) $2R\ \Omega$
- (b) $\frac{4R}{3}\ \Omega$
- (c) $\frac{2R}{3}\ \Omega$
- (d) $R\ \Omega$

19.

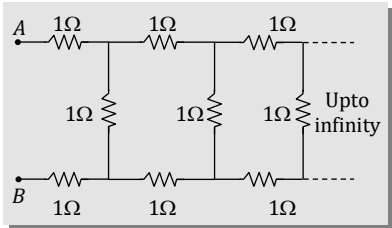

- (a) $(\sqrt{3} - 1)$
- (b) $(1 - \sqrt{3})$
- (c) $(1 + \sqrt{3})$
- (d) $(2 + \sqrt{3})$

20.

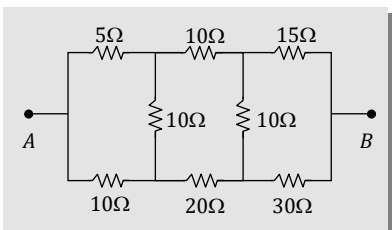

- (a) $20\ \Omega$
- (b) $30\ \Omega$
- (c) $90\ \Omega$
- (d) $110\ \Omega$

21.

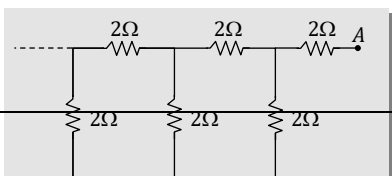

- (a) Less than $4\ \Omega$
- (b) $4\ \Omega$
- (c) More than $4\ \Omega$ but less than $12\ \Omega$
- (d) $12\ \Omega$

22.

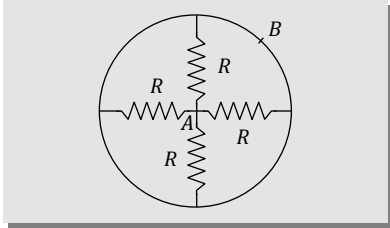

- (a) $\frac{R}{4}$
- (b) $4R$
- (c) $\frac{3R}{4}$
- (d) $\frac{4R}{3}$

23.

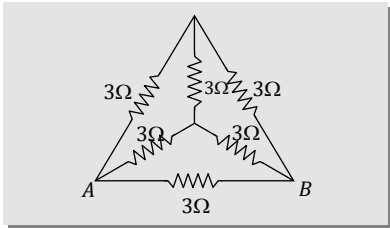

- (a) 4 ohms
- (b) 2 ohms
- (c) 1 ohm
- (d) $\frac{6}{4}$ ohm

24.

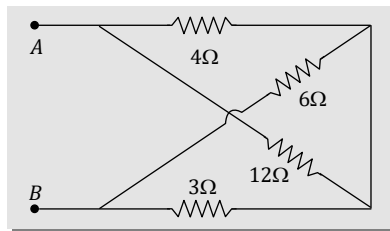

- (a) $6\ \Omega$
- (b) $16\ \Omega$
- (c) $7\ \Omega$
- (d) $5\ \Omega$

25.

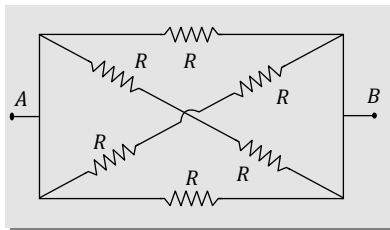

- (a) R
- (b) $\frac{R}{3}$
- (c) $3R$
- (d) $4R$

26.

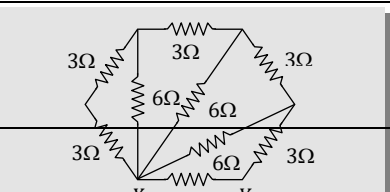

- (a) $4\ \Omega$
- (b) $2\ \Omega$
- (c) $8\ \Omega$
- (d) $16\ \Omega$

27.

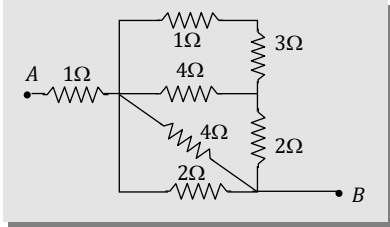

- (a) $1\ \Omega$
- (b) $2\ \Omega$
- (c) $3\ \Omega$
- (d) $4\ \Omega$

28.

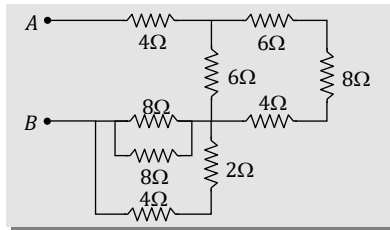

- (a) $4\ \Omega$
- (b) $6\ \Omega$
- (c) $10.9\ \Omega$
- (d) $12.6\ \Omega$

9.

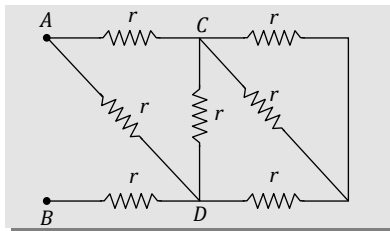

- (a) $\frac{13}{9}r$
- (b) $\frac{11}{5}r$
- (c) $\frac{5}{12}r$
- (d) $\frac{21}{13}r$

30.

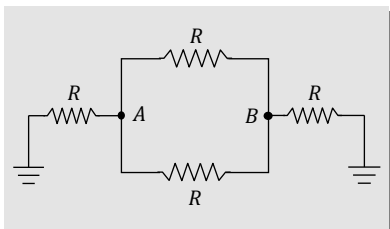

- (a) $\frac{R}{2}$
- (b) $\frac{2R}{5}$
- (c) $\frac{3R}{5}$
- (d) $\frac{R}{3}$

31.

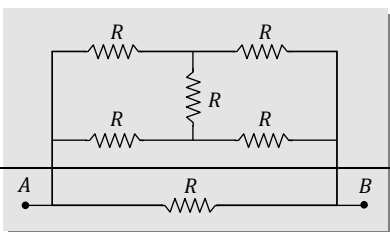

(a) $\frac{R}{2}$

(b) R

(c) $2R$

(d) $4R$

32.

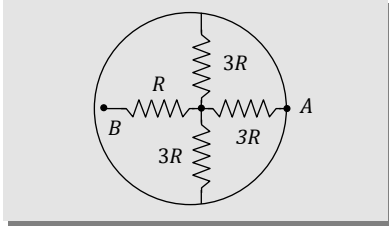

(a) $2R$

(b) $4R$

(c) $7R$

(d) $10R$

33.

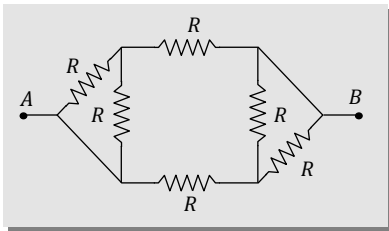

(a) $\frac{3}{4}R$

(b) $\frac{5}{3}R$

(c) $\frac{7}{5}R$

(d) R

34.

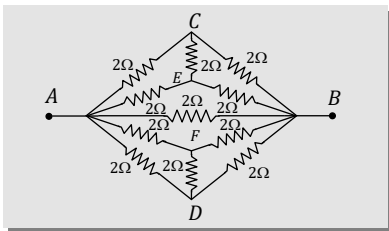

(a) 2Ω

(b) $\frac{2}{3}\Omega$

(c) $\frac{3}{4}\Omega$

(d) $\frac{4}{3}\Omega$

Answersheet

1	2	3	4	5	6	7	8	9	10	11	12	13	14	15	16	17	18	19	20
b	b	b	b	c	a	a	b	c	c	c	c	d	b	d	d	d	a	c	b
21	22	23	24	25	26	27	28	29	30	31	32	33	34	35	36	37	38	39	40
b	d	a	d	a	a	b	a	c	a	d	a	d	d	b	c	b	c	c	a
41	42	43	44	45	46	47	48	49	50	51	52	53	54	55	56	57	58	59	60
b	a	c	d	a	a	d	c	d	a	c	b	a	d	c	b	c	a	c	c
61	62	63	64	65	66	67	68	69	70	71	72	73	74	75	76	77	78	79	80
b	a	c	c	a	b	a	a	c	b	b	b	d	c	c	b	a	c	c	b
81	82	83	84	85	86	87	88	89	90	91	92	93	94	95	96	97	98	99	100
d	b	d	a	c	a	c	d	c	c	d	a	a	a	d	a	c	d	a	b
101	102	103	104	105	106	107	108	109	110	111	112	113	114	115	116	117	118	119	120
a	d	b	b	d	b	d	c	d	c	c	a	b	b	d	a	a	c	a	a
121	122	123	124	125	126	127	128	129	130	131	132	133	134	135	136	137	138	139	140
d	a	b	d	b,c	d	d	d	a	c	c	b	d	c	d	c	a	d	d	b
141	142	143	144	145	146	147	148	149	150	151	152	153	154	155	156	157	158	159	160
a	b	a	a	a	d	b	a	b	a	c	b	a	c	c	d	d	d	c	c
161	162	163	164	165	166	167	168	169	170	171	172	173	174	175	176	177	178	179	180
d	b	b	c	a	b	b	c	b	a	b	a	b	a	c	c	a	b	a	b
181	182	183	184	185	186	187	188	189	190	191	192	193	194	195	196	197	198	199	200
d	a	d	c	d	a	b	b	d	d	d	d	d	b	c	b	c	b	c	b
201	202	203	204	205	206	207	208	209	210	211	212	213	214	215	216	217	218	219	220
c	c	a	a	b	c	c	c	c	c	c	d	d	c	a	a	a	d	a	c
221	222	223	224	225	226	227	228	229	230	231	232	233	234	235	236	237	238	239	240
d	d	a	c	a	c	d	b	d	d	a	a	d	a	b	b	a	a	a	d
241	242	243	244	245	246	247	248	249	250	251	252	253	254	255	256	257	258	259	260
d	c	d	b	d	d	a	d	c	b	a	c	b	b	a	d	a	a	a	b
261	262	263																	
c	b	d																	

Answersheet Practice Network

1	2	3	4	5	6	7	8	9	10	11	12	13	14	15	16	17	18	19	20
c	b	a	a	d	b	c	c	d	d	d	b	d	b	a	c	d	c	c	a
21	22	23	24	25	26	27	28	29	30	31	32	33	34						
c	a	d	a	b	b	b	c	d	a	a	a	a	b						